



**LUNA2000-(5-30)-S0**

# **User Manual**

**Issue 01**

**Date 2020-10-20**

HUAWEI TECHNOLOGIES CO., LTD.



**Copyright © Huawei Technologies Co., Ltd. 2020. All rights reserved.**

No part of this document may be reproduced or transmitted in any form or by any means without prior written consent of Huawei Technologies Co., Ltd.

## **Trademarks and Permissions**



HUAWEI and other Huawei trademarks are trademarks of Huawei Technologies Co., Ltd.

All other trademarks and trade names mentioned in this document are the property of their respective holders.

## **Notice**

The purchased products, services and features are stipulated by the contract made between Huawei and the customer. All or part of the products, services and features described in this document may not be within the purchase scope or the usage scope. Unless otherwise specified in the contract, all statements, information, and recommendations in this document are provided "AS IS" without warranties, guarantees or representations of any kind, either express or implied.

The information in this document is subject to change without notice. Every effort has been made in the preparation of this document to ensure accuracy of the contents, but all statements, information, and recommendations in this document do not constitute a warranty of any kind, express or implied.

## **Huawei Technologies Co., Ltd.**

Address: Huawei Industrial Base  
Bantian, Longgang  
Shenzhen 518129  
People's Republic of China

Website: <https://e.huawei.com>



# About This Document

## Purpose

This document describes the LUNA2000 battery in terms of its overview, application scenarios, installation and commissioning, system maintenance, and technical specifications. The LUNA2000 battery consists of a LUNA2000-5KW-C0 power control module and LUNA2000-5-E0 battery expansion modules.



## Intended Audience

This document is intended for:

- Sales engineers
- System engineers
- Technical support engineers

## Symbol Conventions

The symbols that may be found in this document are defined as follows.

| Symbol   | Description  |
|--|--|
|  <b>DANGER</b>  | Indicates a hazard with a high level of risk which, if not avoided, will result in death or serious injury.  |
|  <b>WARNING</b> | Indicates a hazard with a medium level of risk which, if not avoided, could result in death or serious injury.   |
|  <b>CAUTION</b> | Indicates a hazard with a low level of risk which, if not avoided, could result in minor or moderate injury.   |
| <b>NOTICE</b>  | Indicates warning information about device or environment security which, if not avoided, could result in equipment damage, data loss, performance deterioration, or unanticipated results.<br><br>NOTICE is used to address practices not related to personal injury. |

| Symbol   | Description   |
|--|---|
|  NOTE | Supplements the important information in the main text.<br>NOTE is used to address information not related to personal injury, equipment damage, and environment deterioration. |

## Change History

Changes between document issues are cumulative. The latest document issue contains all the changes made in earlier issues.

### Issue 01 (2020-10-20)

This issue is the first official release.



# Contents

|  |           |
|--|-----------|
| <b>About This Document.....</b>                        | <b>ii</b> |
| <b>1 Safety Precautions.....</b>                       | <b>1</b>  |
| 1.1 General Safety.....                                | 1         |
| 1.2 Personnel Requirements.....                        | 3         |
| 1.3 Electrical Safety.....                             | 4         |
| 1.4 Installation Environment Requirements.....         | 5         |
| 1.5 Transportation Requirements.....                   | 6         |
| 1.6 Mechanical Safety.....                             | 7         |
| 1.7 Commissioning.....                                 | 8         |
| 1.8 Maintenance and Replacement.....                   | 8         |
| <b>2 Product Introduction.....</b>                     | <b>10</b> |
| 2.1 Overview.....                                      | 10        |
| 2.2 Appearance.....                                    | 13        |
| 2.3 Label Description.....                             | 15        |
| 2.4 Features.....                                      | 17        |
| 2.5 Working Mode.....                                  | 18        |
| <b>3 Application Scenarios and Settings.....</b>       | <b>20</b> |
| 3.1 Grid-tied ESS.....                                 | 20        |
| 3.1.1 Grid-tied ESS Networking.....                    | 20        |
| 3.1.2 Setting the Grid-tied ESS Mode.....              | 23        |
| 3.2 Grid-tied and Off-grid ESS.....                    | 28        |
| 3.2.1 Grid-tied and Off-grid ESS Networking.....       | 28        |
| 3.2.2 Setting the Grid-tied and Off-grid ESS Mode..... | 31        |
| 3.3 Pure Off-grid ESS.....                             | 33        |
| 3.3.1 Pure Off-grid ESS Networking.....                | 33        |
| 3.3.2 Setting the Pure Off-grid ESS Mode.....          | 34        |
| <b>4 System Installation.....</b>                      | <b>36</b> |
| 4.1 Checking Before the Installation.....              | 36        |
| 4.2 Preparing Tools and Instruments.....               | 36        |
| 4.3 Determining the Installation Position.....         | 38        |
| 4.4 Equipment Installation.....                        | 39        |
| 4.4.1 Floor-Mounted Installation.....                  | 39        |

|   |           |
|---|-----------|
| 4.4.2 Wall-Mounted Installation.....                    | 44        |
| <b>5 Electrical Connection.....</b>                     | <b>48</b> |
| 5.1 Preparing Cables.....                               | 49        |
| 5.2 Internal Electrical Connections of the Battery..... | 50        |
| 5.2.1 Installing an Internal Ground Cable.....          | 50        |
| 5.2.2 Installing Internal DC Terminals.....             | 51        |
| 5.2.3 Connecting Internal Signal Cables.....            | 52        |
| 5.3 External Electrical Connections of the Battery..... | 53        |
| 5.3.1 Installing a PE Cable.....                        | 54        |
| 5.3.2 Installing DC Input Power Cables.....             | 56        |
| 5.3.3 Installing a Signal Cable.....                    | 57        |
| 5.4 (Optional) Cascading Batteries.....                 | 60        |
| 5.5 Installing the Cover.....                           | 62        |
| <b>6 System Commissioning.....</b>                      | <b>64</b> |
| 6.1 Verification Before Power-On.....                   | 64        |
| 6.2 System Power-On.....                                | 65        |
| 6.3 Battery Commissioning.....                          | 66        |
| 6.3.1 Battery Deployment.....                           | 66        |
| 6.3.2 Battery Control.....                              | 67        |
| 6.3.3 Querying the Battery Status.....                  | 70        |
| 6.3.4 Battery Maintenance and Upgrade.....              | 70        |
| <b>7 System Maintenance.....</b>                        | <b>73</b> |
| 7.1 System Power-Off.....                               | 73        |
| 7.2 Routine Maintenance.....                            | 73        |
| 7.3 Troubleshooting.....                                | 74        |
| 7.4 Battery Storage and Recharge.....                   | 80        |
| <b>8 Technical Specifications.....</b>                  | <b>86</b> |
| 8.1 LUNA2000-5KW-C0.....                                | 86        |
| 8.2 LUNA2000-5-E0.....                                  | 87        |
| <b>9 FAQ.....</b>                                       | <b>88</b> |
| 9.1 How Do I Replace a Fuse?.....                       | 88        |
| <b>A Acronyms and Abbreviations.....</b>                | <b>90</b> |



# 1 Safety Precautions

---

## 1.1 General Safety

### Declaration

Before installing, operating, and maintaining the equipment, read this document and observe all the safety instructions on the equipment and in this document.

The "NOTICE", "WARNING", and "DANGER" statements in this document do not cover all the safety instructions. They are only supplements to the safety instructions. Huawei will not be liable for any consequence caused by the violation of general safety requirements or design, production, and usage safety standards.

Ensure that the equipment is used in environments that meet its design specifications. Otherwise, the equipment may become faulty, and the resulting malfunction, component damage, personal injuries, or property damage are not covered under the warranty.

Follow local laws and regulations when installing, operating, or maintaining the equipment. The safety instructions in this document are only supplements to local laws and regulations.

Huawei will not be liable for any consequences of the following circumstances:

- Operation beyond the conditions specified in this document
- Installation or use in environments which are not specified in relevant international or national standards
- Unauthorized modifications to the product or software code or removal of the product
- Failure to follow the operation instructions and safety precautions on the product and in this document
- Equipment damage due to force majeure, such as earthquakes, fire, and storms
- Damage caused during transportation by the customer
- Damage caused by storage conditions that do not meet the requirements specified in related documents

## General Requirements

---

 **DANGER**

Do not work with power on during installation.

---

- Do not install, use, or operate outdoor equipment and cables (including but not limited to moving equipment, operating equipment and cables, inserting connectors to or removing connectors from signal ports connected to outdoor facilities, working at heights, and performing outdoor installation) in harsh weather conditions such as lightning, rain, snow, and level 6 or stronger wind.
- After installing the equipment, remove idle packing materials such as cartons, foam, plastics, and cable ties from the equipment area.
- In the case of a fire, immediately leave the building or the equipment area, and turn on the fire alarm bell or make an emergency call. Do not enter the building on fire in any case.
- Do not scrawl, damage, or block any warning label on the equipment.
- Tighten screws using tools when installing the equipment.
- Understand the components and functioning of a grid-tied PV power system and relevant local standards.
- Repaint any paint scratches caused during equipment transportation or installation in a timely manner. Equipment with scratches cannot be exposed to an outdoor environment for a long period of time.
- Do not open the host panel of the equipment.
- Without prior consent from the manufacturer, do not alter the internal structure or installation procedure of the equipment.
- Ensure that battery terminal components are not affected during transportation. Do not hoist or move batteries by using battery terminal bolts.

## Personal Safety

- Wear proper personal protective equipment (PPE) during operation. If there is a probability of personal injury or equipment damage, immediately stop the operations, report the case to the supervisor, and take feasible protective measures.
- Use tools correctly to avoid hurting people or damaging the equipment.
- Do not touch the energized equipment, as the enclosure is hot.
- To ensure personal safety and normal use of the equipment, the equipment must be reliably grounded before use.
- When a battery is faulty, the temperature may exceed the burn threshold of the touchable surface. Therefore, avoid touching the battery.
- Do not disassemble or damage the battery. The released electrolyte is harmful to your skin and eyes. Avoid contact with the electrolyte.
- Do not place irrelevant objects on the top of the equipment or insert them into any position of the equipment.
- Do not place inflammables around the equipment.

- To prevent explosions and body injury, do not place batteries in a fire.
- Do not place the battery module in water or other liquids.
- Do not short-circuit wiring terminals of batteries. Short circuits can cause a fire.
- Batteries may cause electric shocks and high short-circuit currents. When using the battery, pay attention to the following points:
  - (a) Remove any metal objects from yourself, such as watches and rings.
  - (b) Use tools with insulated handles.
  - (c) Wear rubber gloves and boots.
  - (d) Do not place tools or metal parts on top of batteries.
  - (e) Before connecting or disconnecting battery terminals, disconnect the charging power supply.
  - (f) Check whether batteries are accidentally grounded. If it is accidentally grounded, remove the power supply from the ground. Touching any part of a grounded battery can cause an electric shock. If these grounding points are removed during installation and maintenance, the possibility of electric shocks can be reduced.
- Do not use water to clean electrical components inside or outside of a cabinet.
- Do not stand on, lean on, or sit on the top of the equipment.
- Do not damage the modules of the equipment.

## 1.2 Personnel Requirements

- Personnel who plan to install or maintain Huawei equipment must receive thorough training, understand all necessary safety precautions, and be able to correctly perform all operations.
- Only qualified professionals or trained personnel are allowed to install, operate, and maintain the equipment.
- Only qualified professionals are allowed to remove safety facilities and inspect the equipment.
- Personnel who will operate the equipment, including operators, trained personnel, and professionals, should possess the local national required qualifications in special operations such as high-voltage operations, working at heights, and operations of special equipment.
- Only professionals or authorized personnel are allowed to replace the equipment or components (including software).

### NOTE

- Professionals: personnel who are trained or experienced in equipment operations and are clear of the sources and degree of various potential hazards in equipment installation, operation, and maintenance
- Trained personnel: personnel who are technically trained, have required experience, are aware of possible hazards on themselves in certain operations, and are able to take protective measures to minimize the hazards on themselves and other people
- Operators: operation personnel who may come in contact with the equipment, except trained personnel and professionals



## 1.3 Electrical Safety

### Grounding Requirements

- For the equipment that needs to be grounded, install the protective earthing (PE) cable first when installing the equipment and remove the PE cable last when removing the equipment.
- Do not damage the ground conductor.
- Do not operate the equipment in the absence of a properly installed ground conductor.
- Ensure that the equipment is connected permanently to the protective ground. Before operating the equipment, check the electrical connection to ensure that it is securely grounded.

### General Requirements

---

 **DANGER**

Before connecting cables, ensure that the equipment is intact. Otherwise, electric shocks or fire may occur.

---

- Ensure that all electrical connections comply with local electrical standards.
- Obtain approval from the local electric utility company before using the equipment in grid-tied mode.
- Ensure that the cables you prepared meet local regulations.
- Use dedicated insulated tools when performing high-voltage operations.

### DC Operation

---

 **DANGER**

Do not connect or disconnect power cables with power-on. Transient contact between the core of the power cable and the conductor will generate electric arcs or sparks, which may cause fire or personal injury.

---

- Before connecting cables, switch off the disconnecter on the upstream equipment to cut off the power supply if people may contact energized components.
- Before connecting a power cable, check that the label on the power cable is correct.
- If the equipment has multiple inputs, disconnect all the inputs before operating the equipment.

## Cabling Requirements

- When routing cables, ensure that a distance of at least 30 mm exists between the cables and heat-generating components or areas. This prevents damage to the insulation layer of the cables.
- Bind cables of the same type together. When routing cables of different types, ensure that they are at least 30 mm away from each other.
- Ensure that the cables used in a grid-tied PV power system are properly connected and insulated and meet specifications.

## 1.4 Installation Environment Requirements

- Install the battery in a dry and well-ventilated environment to ensure good heat dissipation.
- You are advised to install the battery in a sheltered place or install an awning over it.
- Install the battery in a clean environment that is free from sources of strong infrared radiation, organic solvents, and corrosive gases. Avoid exposing the battery to direct sunlight or water.
- The installation position must be far away from fire sources.
- Children are not allowed to enter the installation position.
- The installation position must be far away from water sources such as taps, sewer pipes, and sprinklers to prevent water seepage.
- The battery must be placed on a solid and flat supporting surface.
- Do not place any flammable or explosive materials around the battery.
- To prevent fire due to high temperature, ensure that the ventilation vents or heat dissipation system are not blocked when the battery is running.
- Do not expose the battery to flammable or explosive gas or smoke. Do not perform any operation on the battery in such environments.
- The battery system site must be equipped with qualified fire extinguishing facilities, such as fire extinguishing sands and powder fire extinguishers.

Figure 1-1 Installation environment

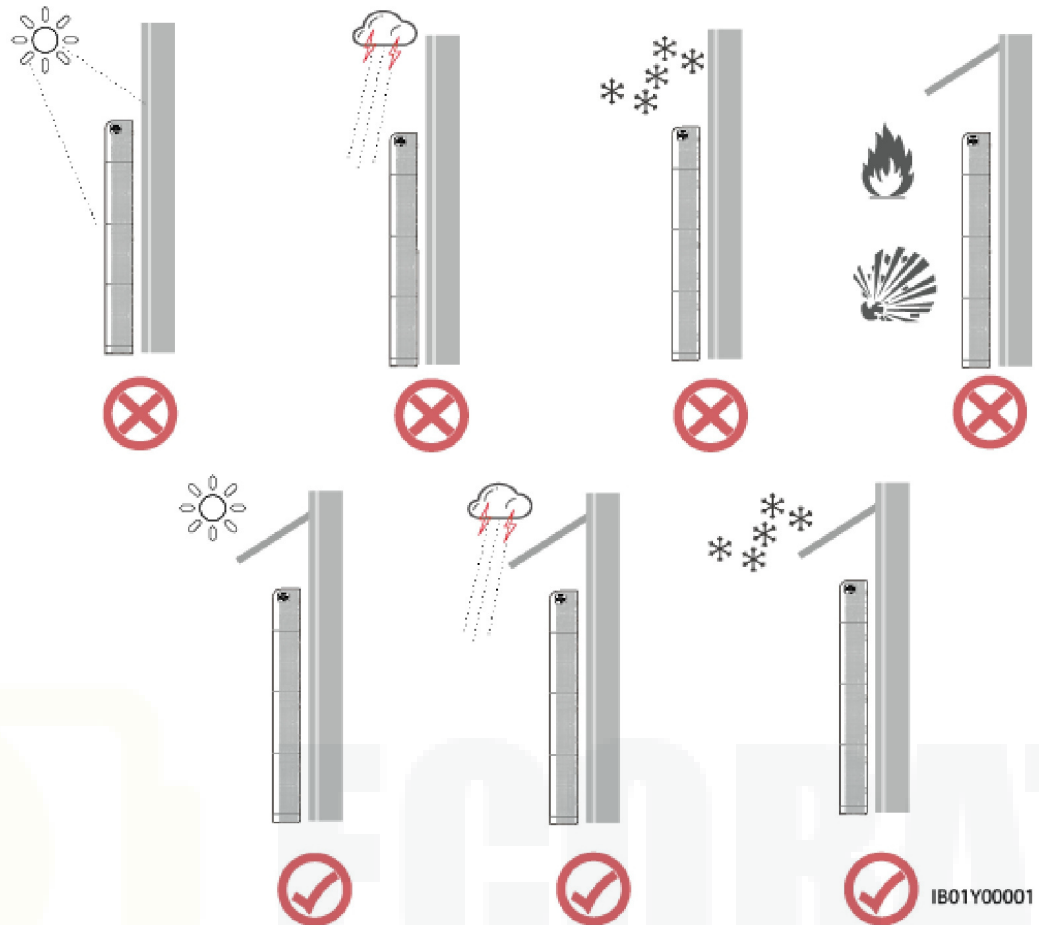

**CAUTION**

The operation and service life of the battery depend on the operating temperature. Install the battery at a temperature equal to the ambient temperature or in a better environment. The recommended operating temperature ranges from 15°C to 30°C.

## 1.5 Transportation Requirements

The product passes the certifications of the UN38.3 (UN38.3: Section 38.3 of the Sixth Revised Edition of the Recommendations on the Transport of Dangerous Goods, Manual of Tests and Criteria) and SN/T 0370.2-2009 (Part 2: Performance Test of the Rules for the Inspection of Packaging for Exporting Dangerous Goods). This product belongs to class 9 dangerous goods.

The product can be delivered to the site directly and transported by land and water. The packing case must be secured for transportation, compliant with related China standards, and printed with marks such as anti-collision and moisture prevention. Affected by external environment factors, such as temperature, transportation, and storage, the product specifications at the delivery date prevail.

Protect the packing case with the product from the following situations:

- Being dampened by rains, snows, or falling into water
- Falling or mechanical impact
- Being upside-down or tilted

## 1.6 Mechanical Safety

### Using Ladders

- Use wooden or fiberglass ladders when you need to perform live working at heights.
- When a step ladder is used, ensure that the pull ropes are secured and the ladder is held firm.
- Before using a ladder, check that it is intact and confirm its load bearing capacity. Do not overload it.
- Ensure that the wider end of the ladder is at the bottom, or protective measures have been taken at the bottom to prevent the ladder from sliding.
- Ensure that the ladder is securely positioned. The recommended angle for a ladder against the floor is 75 degrees, as shown in the following figure. An angle rule can be used to measure the angle.

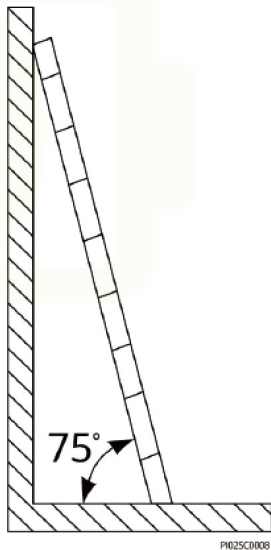

- When climbing a ladder, take the following precautions to reduce risks and ensure safety:
  - Keep your body steady.
  - Do not climb higher than the fourth rung of the ladder from the top.
  - Ensure that your body's center of gravity does not shift outside the legs of the ladder.

### Drilling Holes

When drilling holes into a wall or floor, observe the following safety precautions:

- Wear goggles and protective gloves when drilling holes.
- When drilling holes, protect the equipment from shavings. After drilling, clean up any shavings that have accumulated inside or outside the equipment.

## Moving Heavy Objects

- Be cautious to avoid injury when moving heavy objects.

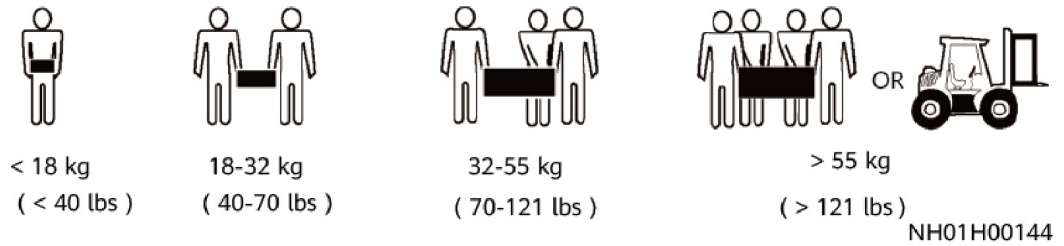

- When moving the equipment by hand, wear protective gloves to prevent injuries.

## 1.7 Commissioning

When the equipment is powered on for the first time, ensure that professional personnel set parameters correctly. Incorrect settings may result in inconsistency with local certification and affect the normal operation of the equipment.

## 1.8 Maintenance and Replacement

### DANGER

High voltage generated by the equipment during operation may cause an electric shock, which could result in death, serious injury, or serious property damage. Prior to maintenance, power off the equipment and strictly comply with the safety precautions in this document and relevant documents.

- Maintain the equipment with sufficient knowledge of this document and using proper tools and testing equipment.
- Before maintaining the equipment, power it off and follow the instructions on the delayed discharge label to ensure that the equipment is powered off.
- Place temporary warning signs or erect fences to prevent unauthorized access to the maintenance site.
- If the equipment is faulty, contact your dealer.
- The equipment can be powered on only after all faults are rectified. Failing to do so may escalate faults or damage the equipment.
- Do not open the cover without authorization. Otherwise, electric shocks may occur, and the resulting faults are beyond warranty scope.
- Installation personnel, maintenance personnel, and technical support personnel must be trained to operate and maintain the equipment safely and correctly, take comprehensive precautionary measures, and be equipped with protective instruments.
- Before moving or reconnecting the equipment, disconnect the mains and batteries and wait for five minutes until the equipment powers off. Before maintaining the equipment, check that no dangerous voltages remain in the DC bus or components to be maintained by using a multimeter.



- Battery maintenance should be carried out or supervised by personnel who are familiar with batteries and the precautions required.
- When replacing batteries, replace them with batteries or battery strings of the same type.
- Take out all tools and parts from the equipment after maintenance is complete.
- If the equipment is not used for a long time, store and recharge batteries according to this document.



# 2 Product Introduction

## 2.1 Overview

### Function

The LUNA2000 battery consists of a power control module and battery expansion modules. It can store and release electric energy based on the requirements of the inverter management system. The input and output ports of the LUNA2000 battery are high-voltage direct current (HVDC) ports.

- Battery charge: The power control module connects to the battery terminals (BAT+ and BAT-) of the inverter. Under the control of the inverter, the power control module charges the batteries and stores excessive PV energy in batteries.
- Battery discharge: When the PV energy is insufficient to supply power to the loads, the system controls the batteries to supply power to the loads. The battery energy is output to the loads through the inverter.

### Model

- Model of the power control module in the LUNA2000 battery:  
LUNA2000-5KW-C0

Figure 2-1 Model number

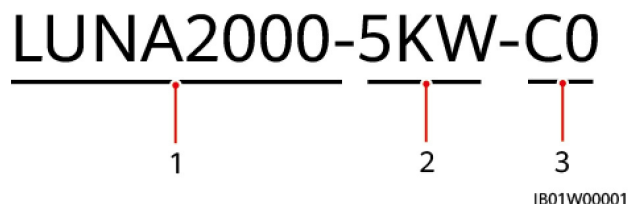

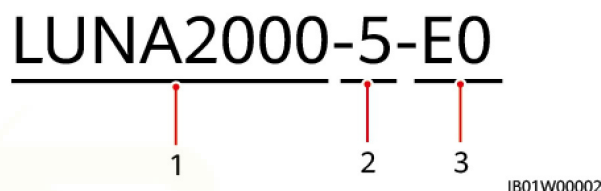

**Table 2-1** Model description

| No. | Meaning     | Value  |
|-----|-------------|--|
| 1   | Product     | LUNA2000: LUNA2000 battery                     |
| 2   | Power level | 5KW: The power level is 5 kW.                  |
| 3   | Design code | C0: product series of the power control module |

- Model of battery expansion modules in the LUNA2000 battery: LUNA2000-5-E0

**Figure 2-2** Model number

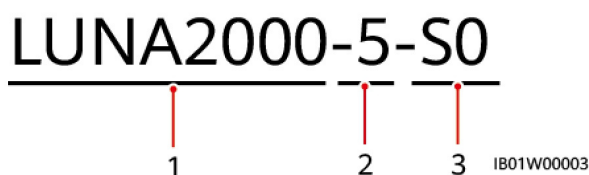

**Table 2-2** Model description

| No. | Meaning      | Value                         |
|-----|--------------|-------------------------------|
| 1   | Product      | LUNA2000: residential battery |
| 2   | Energy level | 5: The energy level is 5 kWh. |
| 3   | Design code  | E0: battery pack module       |

- The model of the LUNA2000 battery is LUNA2000-5-S0.

**Figure 2-3** Model number



**Table 2-3** Model description

| No. | Meaning      | Value  |
|-----|--------------|--|
| 1   | Product      | LUNA2000: residential battery  |
| 2   | Energy level | 5: The capacity level is 5 kWh. This product supports 5 kWh to 30 kWh. |

| No. | Meaning     | Value       |
|-----|-------------|-------------|
| 3   | Design code | S0: battery |

### Battery Capacity Description

The battery supports power and capacity expansion. Two power control modules can be connected in parallel. One power control module supports a maximum of three battery expansion modules.

Figure 2-4 Battery capacity description

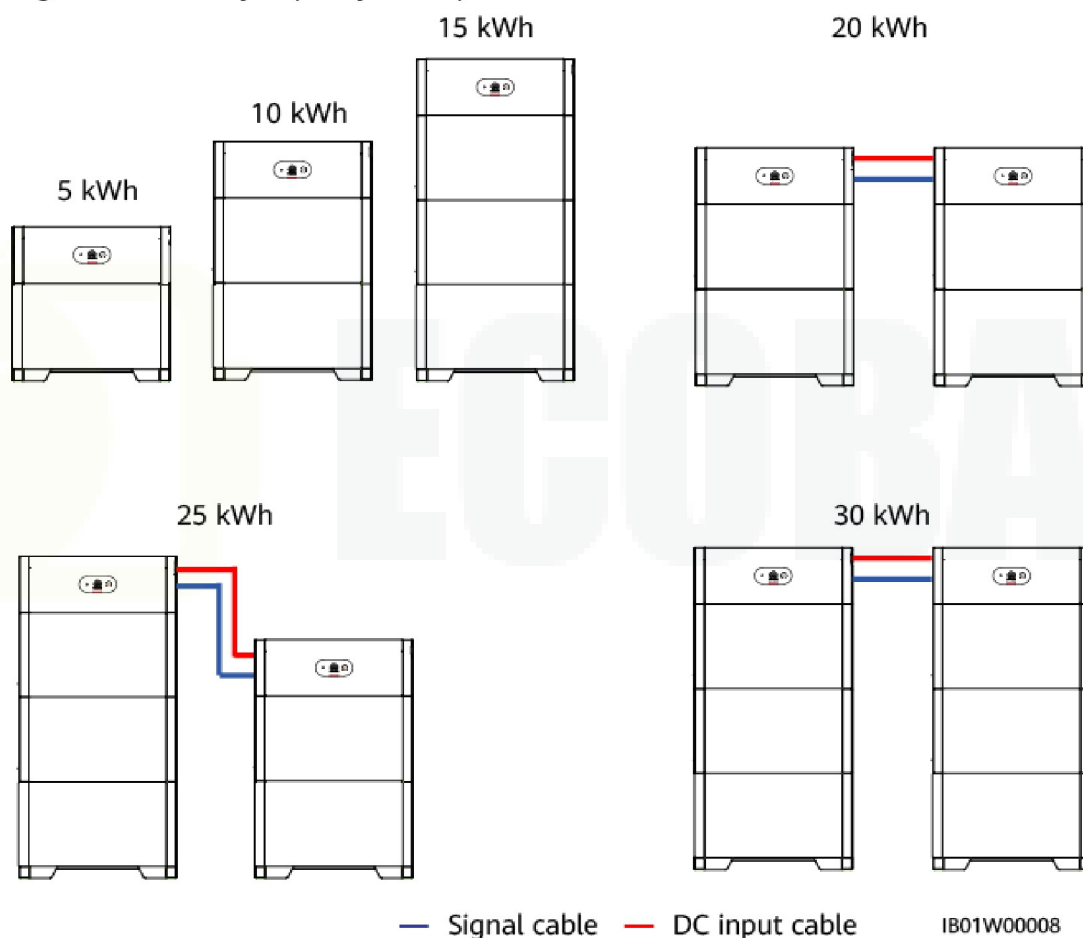

### Networking Application

The LUNA2000 battery is applicable to the grid-tied systems of residential rooftop PV plants. Typically, a grid-tied system consists of PV strings, LUNA2000 batteries, an inverter, an AC switch, and a power distribution box (PDB).

**Figure 2-5** Networking (dashed boxes indicate optional components)

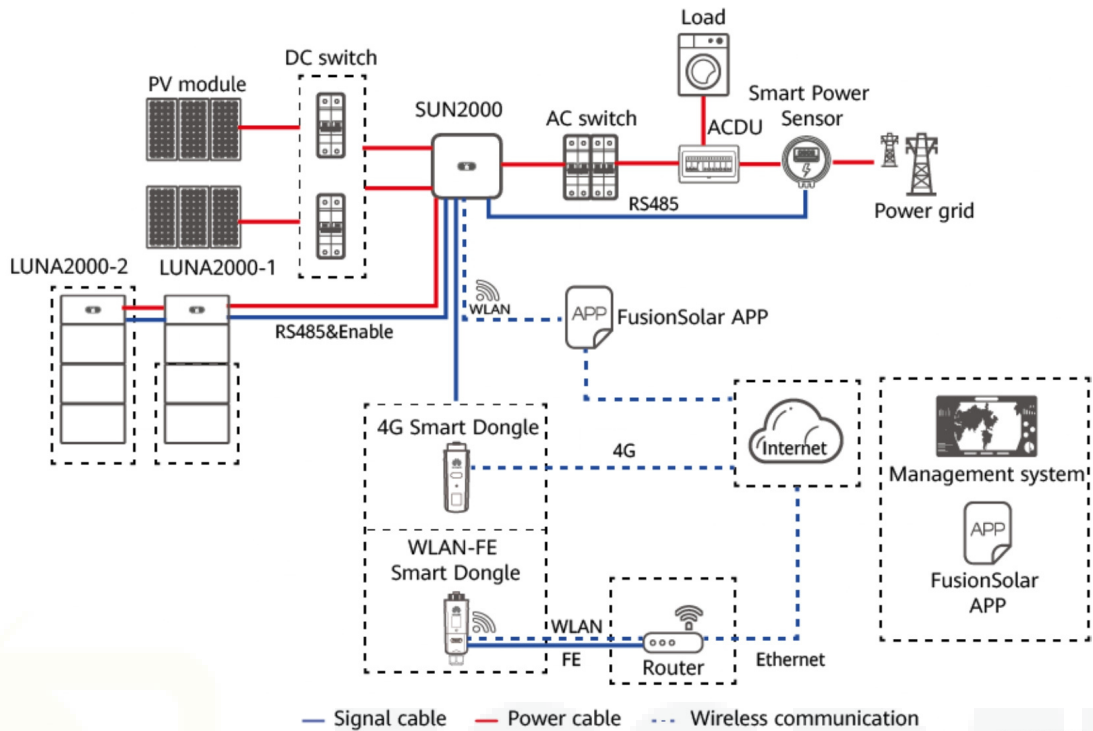

IB01N10001

- The input and output ports of the LUNA2000 battery are connected to the battery ports of the inverter.
- The following communication modes are supported by the LUNA2000 battery:
  - Connect the LUNA2000 battery to the inverter over the RS485 port and Enable port to implement communication and control between the inverter and the LUNA2000 battery.
  - Use the mobile phone App to directly connect to the inverter or connect to the inverter in the same LAN to manage and maintain the LUNA2000 battery.
  - Connect the inverter to the public network through the Smart Dongle to manage and maintain the LUNA2000 battery through the management system.

## 2.2 Appearance

### Battery

This topic describes the battery appearance.

**Figure 2-6 Battery appearance**

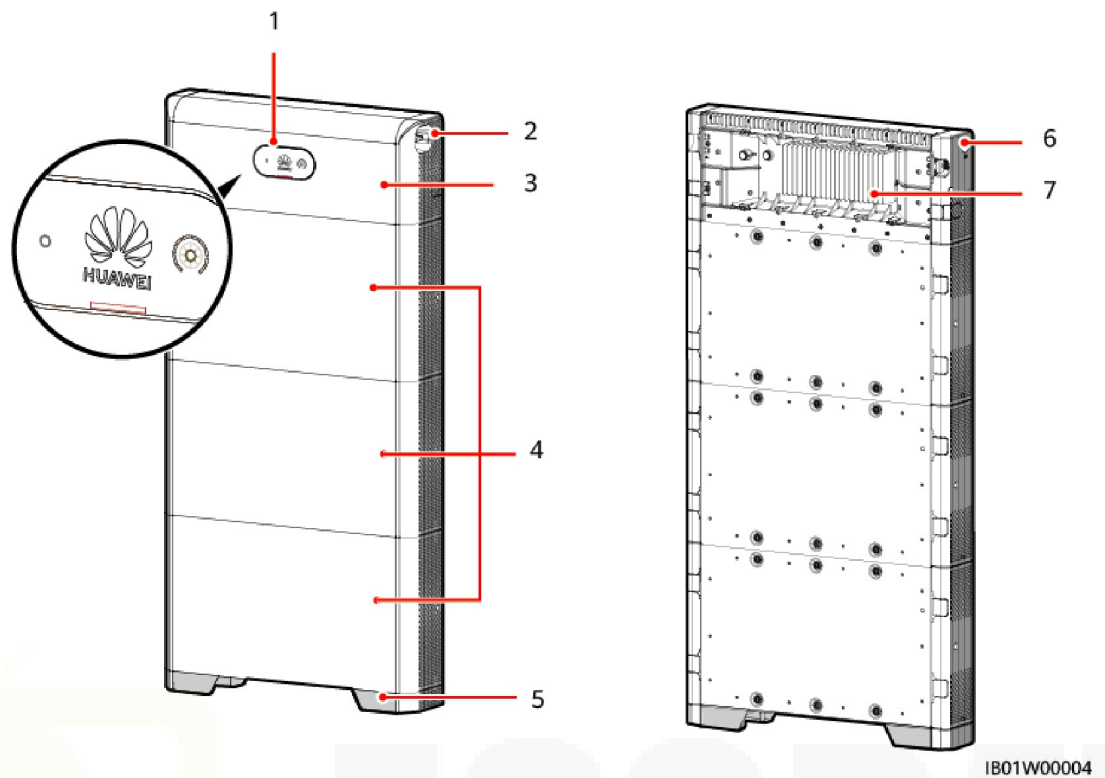

(1) LED indicator

(2) DC switch (DC SWITCH)

(3) Power control module

(4) Battery expansion modules

(5) Installation base

(6) Black start switch

(7) Heat sink

## Power Control Module

The power of the power control module is 5 kW.

**Figure 2-7 Power control module**

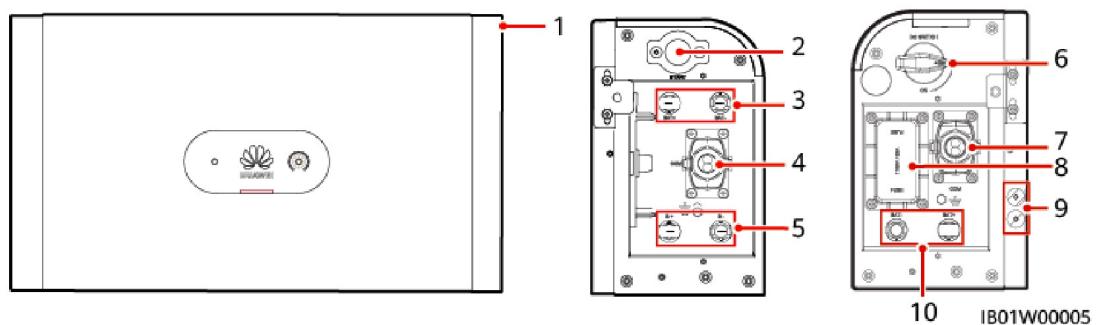

- |                                    |   |                                   |
|------------------------------------|---|-----------------------------------|
| (1) Power control module           | (2) Black start switch                  | (3) Battery terminals (BAT+/BAT-) |
| (4) COM port (COM)                 | (5) Battery cascading terminals (B+/B-) | (6) DC switch (DC SWITCH)         |
| (7) COM port (COM)                 | (8) Fuse                                | (9) Ground point                  |
| (10) Battery terminals (BAT+/BAT-) |   |                                   |

### Battery Expansion Module

The standard capacity of a battery expansion module is 5 kWh.

**Figure 2-8** Battery expansion module

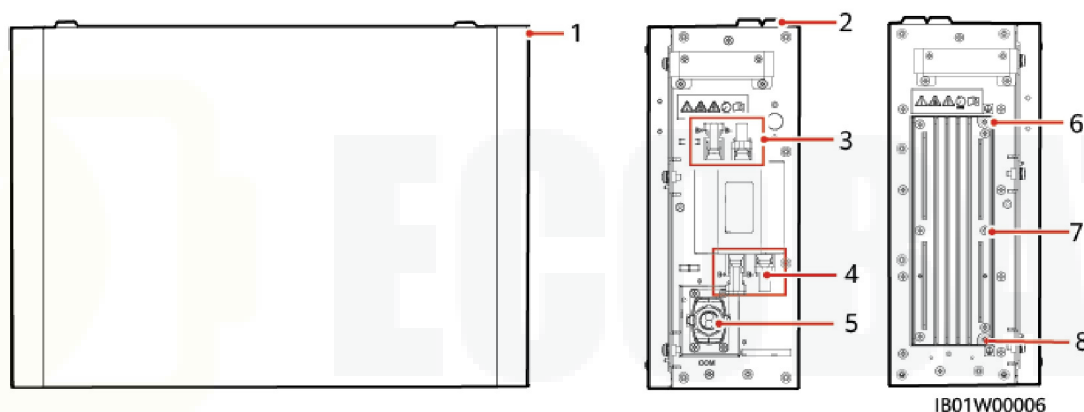

- |   |                        |   |
|---|------------------------|---|
| (1) Battery expansion module            | (2) Boss for alignment | (3) Battery cascading terminals (B+/B-) |
| (4) Battery cascading terminals (B+/B-) | (5) COM port (COM)     | (6) Ground point                        |
| (7) Heat sink                           | (8) Ground point       |   |

## 2.3 Label Description

## Enclosure Labels

Table 2-4 Enclosure label description

| Icon | Name                   | Meaning   |
|------|------------------------|---|
|      | Burn warning           | Do not touch the product, as the shell is hot when it is running.   |
|      | Delayed discharge      | <ul style="list-style-type: none"> <li>High voltage exists after the battery is powered off. It takes 5 minutes for the battery to discharge to the safe voltage.</li> </ul>  |
|      | Operator               | <ul style="list-style-type: none"> <li>High voltage exists after the battery is powered on. Only qualified and trained electrical technicians are allowed to install and operate the battery.</li> <li>Ground the battery before powering it on.</li> </ul> |
|      | Refer to documentation | Reminds operators to refer to the documentation provided with the equipment.  |
|      | Grounding              | Indicates the position for connecting the PE cable.   |

### NOTE

The labels are for reference only.

## Nameplate

Nameplate of a power control module



Figure 2-9 Nameplate (power control module)

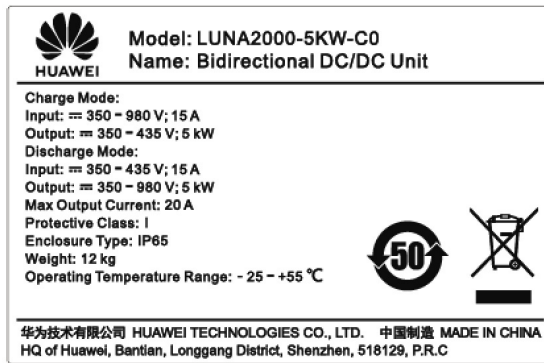
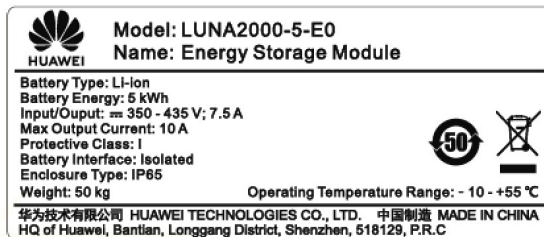

Figure 2-10 Nameplate (battery expansion module)



## 2.4 Features

### Multi-Scenario and Multi-Working Mode

- Supports multiple working modes such as grid-tied, grid-tied and off-grid, pure off-grid multi-scenario, self-consumption, time-of-use, and full fed to the grid modes.
- Allows users to query the total discharge capacity in the product life cycle in real time.

### Intelligent and Simple Operation

Works with the inverter, supports plug-and-play, and integrates the mobile phone app and management system.

### Easy Installation and Replacement

- Standard battery DC terminals are used for system connection.
- Modular design is adopted for batteries.
- The installation or replacement can be performed by two persons.

### Flexible Scalability

The battery supports power expansion, battery capacity expansion, and hybrid use of old and new batteries.

### Intelligent O&M

- The factory defaults meet the requirements of target markets and the battery can be started by pressing only one button and supports black startup.



- The LED indicator shows the status. You can also use the mobile phone app to perform local and remote operations.
- The cloud data management system is used to manage the battery anytime and anywhere.

### Low Investment

- Only common installation tools are required.
- The battery features high efficiency and power density, which saves installation space.
- The battery features easy O&M.

## 2.5 Working Mode

The LUNA2000 converts HVDC generated by PV strings into low-voltage direct current (LVDC) through DC-to-DC conversion and stores the power in batteries. It can also convert LVDC into HVDC and feed the power into the power grid through the inverter.

### Working Mode

The LUNA2000 battery can work in hibernation, standby, or operating mode.

Table 2-5 Working mode

| Working Mode     | Description  |
|------------------|--|
| Hibernation mode | The internal auxiliary power source and DC-DC converter of the battery do not work.                      |
| Standby mode     | The auxiliary power source inside the battery works, and the DC-DC converter does not work.              |
| Operating mode   | The internal auxiliary power source of the battery works, and the DC-DC converter charges or discharges. |

Figure 2-11 Switchover among working modes

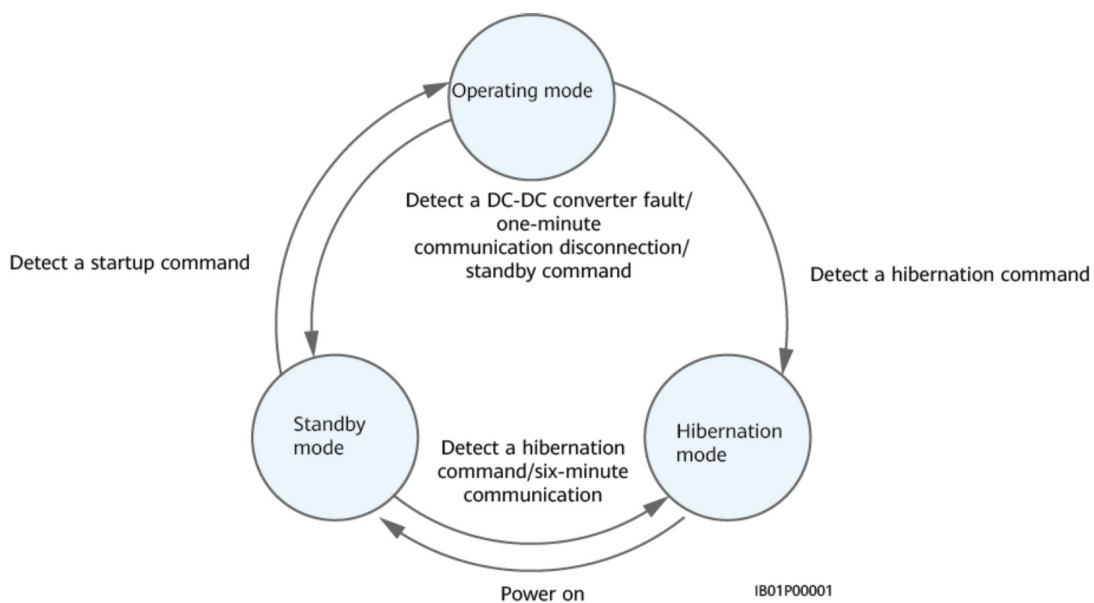

# 3 Application Scenarios and Settings

---

The LUNA2000 battery is mainly used in grid-tied systems of residential rooftop PV plants. The system can be classified into the following three types based on application scenarios:

- Grid-tied energy storage system (ESS)
- Grid-tied and off-grid ESS
- Off-grid ESS

Multiple working modes can be set, such as maximum self-consumption, time-of-use, and fully fed to the grid.

## 3.1 Grid-tied ESS

### 3.1.1 Grid-tied ESS Networking

#### Networking 1: Inverter + Batteries

The grid-tied ESS consists of the PV strings, LUNA2000 batteries, inverter, AC switch, load, power distribution unit (PDU), and grid.

The SUN2000-(2KTL-6KTL)-L1 or SUN2000-(3KTL-10KTL)-M1 inverters are supported.

The PV string converts solar energy into electric energy, which is then converted by the inverter into power for loads and then fed to the power grid.

**Figure 3-1** Grid-tied ESS networking diagram (dashed boxes indicate optional components)

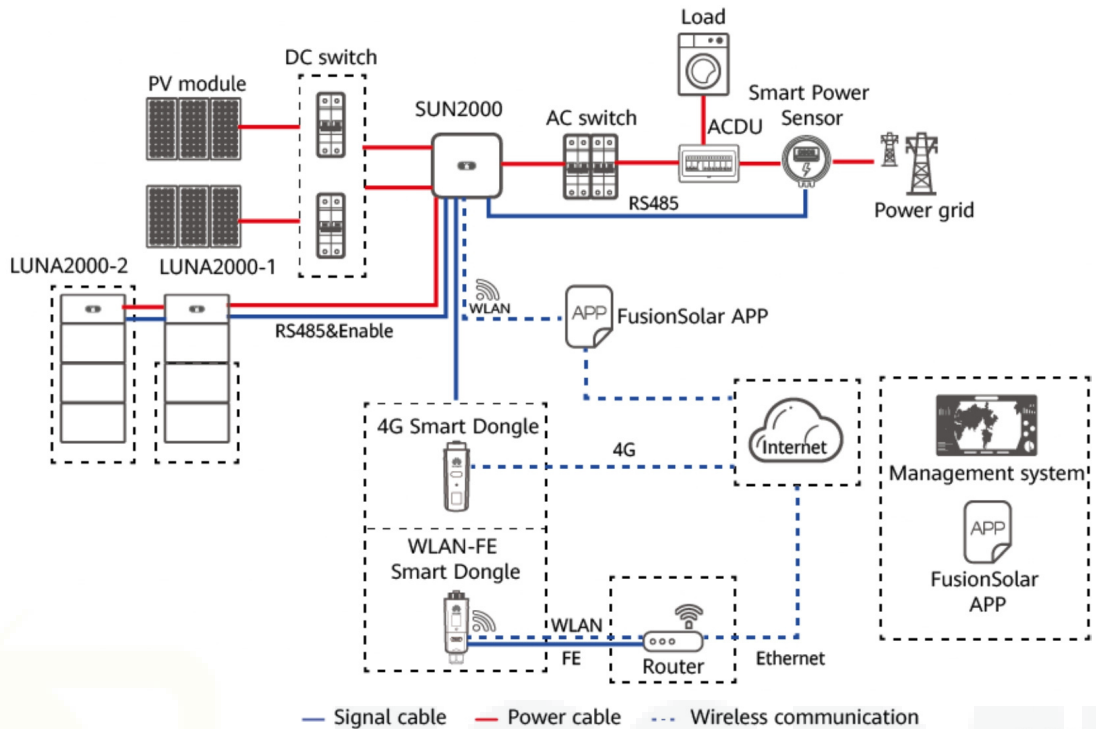

IB01N10001

## Networking 2: Inverter (with Batteries) + Inverter (Without Batteries)

The grid-tied ESS supports inverter cascading. A maximum of three inverters can be cascaded. The batteries can be connected to one of the inverters for management. The batteries, power meter, and Smart Dongle need to be connected to the same inverter.

**Figure 3-2** Inverter (with batteries) + inverter (without batteries) (dashed boxes indicate optional components)

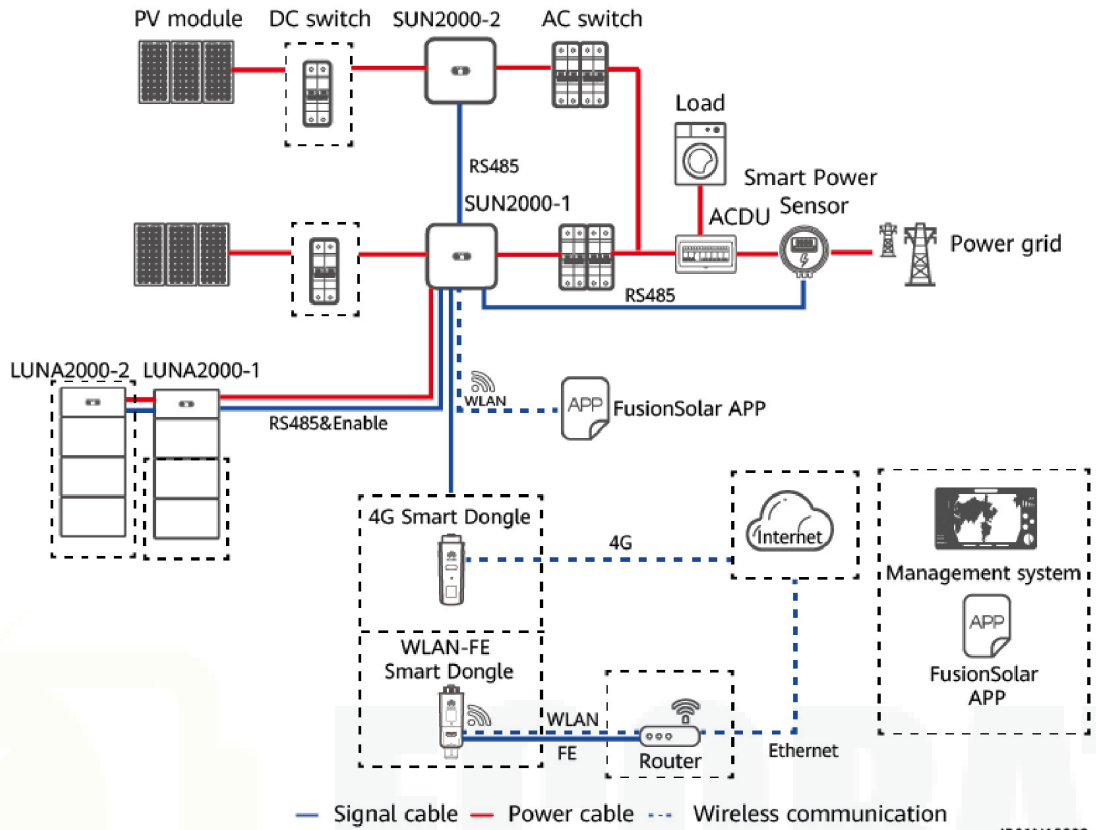

**Table 3-1** Mapping relationship

| Inverter | SUN2000-1  | SUN2000-2  |
|----------|--|--|
| Model    | SUN2000-(2KTL-6KTL)-L1/<br>SUN2000-(3KTL-10KTL)-M1 | SUN2000-(2KTL-6KTL)-L1/SUN2000-<br>(3KTL-10KTL)-M1 |

**NOTE**

When the grid charging function is enabled, the surplus power generated by the inverter without batteries can be used to charge the inverter connected to the batteries.

**Networking 3: Inverter (with Batteries) + Inverter (with Batteries)**

When the capacity requirement is high, you can add inverters and batteries. A maximum of three inverters can be cascaded. Each battery connects to the inverter through an independent RS485 port and is managed by the inverter connected to it.

**Figure 3-3** Inverter (with batteries) + inverter (with batteries) (dashed boxes indicate optional components)

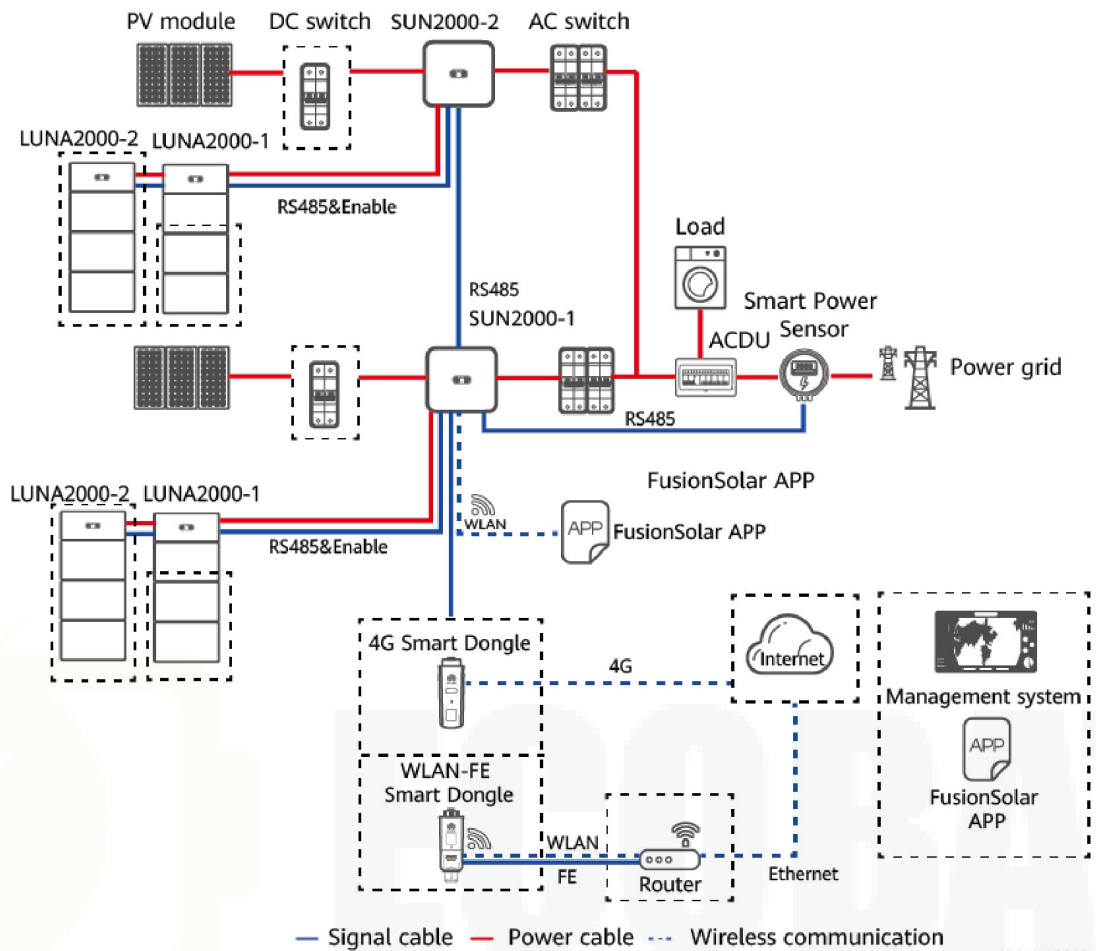

**Table 3-2** Mapping relationship

| Inverter | SUN2000-1  | SUN2000-2  |
|----------|--|--|
| Model    | SUN2000-(2KTL-6KTL)-L1/<br>SUN2000-(3KTL-10KTL)-M1 | SUN2000-(2KTL-6KTL)-L1/SUN2000-<br>(3KTL-10KTL)-M1 |

**NOTE**

The parameters of each battery need to be set separately. When the grid charging function is enabled, the surplus power generated by one inverter can be used to charge the other inverter.

### 3.1.2 Setting the Grid-tied ESS Mode

The grid-tied ESS has three main working modes: self-consumption, time-of-use, and excess fed to the grid.

## Self-Consumption

- This mode applies to areas where the electricity price is high, or areas where the FIT subsidy is low or unavailable.
- Excess PV energy is stored in batteries. When PV power is insufficient or no PV power is generated at night, batteries discharge to supply power to the loads, improving the self-consumption rate of the PV system and the self-sufficiency rate of residential energy, and reducing electricity costs.
- In this mode, **Maximum self-consumption** is selected. By default, the charge cutoff capacity is 100% and the discharge cutoff capacity is 0% for Huawei LUNA2000 batteries. For details about how to change the charge or discharge cutoff capacity, see [6.3 Battery Commissioning](#).

Figure 3-4 Battery control parameter setting

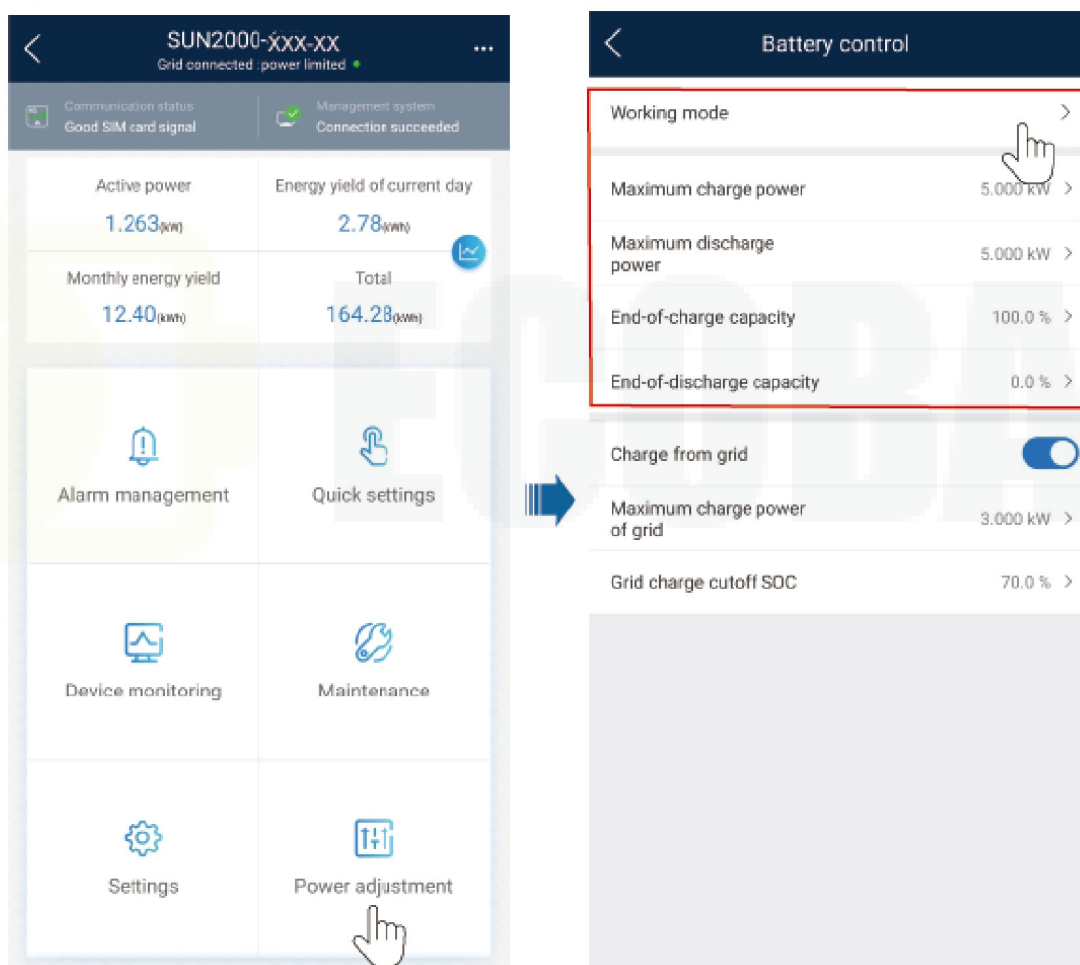



| Parameter                     | Description   | Value Range  |
|-------------------------------|---|--|
| Working mode                  | Set this parameter to the maximum self-consumption mode.  | <ul style="list-style-type: none"> <li>Maximum self-consumption</li> <li>Time-of-use</li> <li>Fully fed to grid</li> </ul> |
| Maximum charge power (kW)     | Retain this parameter to the maximum charge power. Additional configuration is not required.    | <ul style="list-style-type: none"> <li>[0, Maximum charge power]</li> </ul>  |
| Maximum discharge power (kW)  | Retain this parameter to the maximum discharge power. Additional configuration is not required. | <ul style="list-style-type: none"> <li>[0, Maximum discharge power]</li> </ul>   |
| End-of-charge capacity (%)    | Set the charge cutoff capacity.   | 80%–100%   |
| End-of-discharge capacity (%) | Set the discharge cutoff capacity.  | 0%–20%   |

## Example of Self-Consumption

Examples of self-consumption:

(1) When the sunlight is sufficient, the PV module outputs 8 kW power, the inverter outputs 5 kW power, the loads consume 4 kW power, and the batteries charge 1 kW power.

(2) When the sunlight becomes weak, the PV module outputs 4 kW power, the inverter outputs 2 kW power, the loads consume 4 kW power, and the batteries discharge to supply 1 kW power to the loads.

## Time-of-Use

- This mode applies to scenarios where the price difference between peak and off-peak hours is large.
- In this mode, **Time-of-use** is selected. You can manually set the charge and discharge time segments. For example, you can allow the grid to charge batteries in low electricity price periods at night and discharge batteries during high electricity price periods, saving electricity fee. The charge from grid function must be enabled.
- A maximum of 14 time segments can be set. For details about how to set charge and discharge parameters, see [6.3 Battery Commissioning](#).

- In some countries, the grid is not allowed to charge batteries. Therefore, this mode cannot be used.
- If the charge time is set but the discharge time is not set, in the charge time segment, the grid can charge the batteries. In other time segments, the batteries work in self-consumption mode. When the PV power is insufficient, the batteries can supply power to loads.

If both the charge time and discharge time are set, the grid charges batteries during the charge time and supplies power to loads during the discharge time. In other time segments that are not set, the batteries do not discharge, and the PV modules and grid supply power to loads. (In grid-tied and off-grid mode, if the grid is powered off, the batteries can discharge at any time.)

**Figure 3-5** Time-of-use working mode

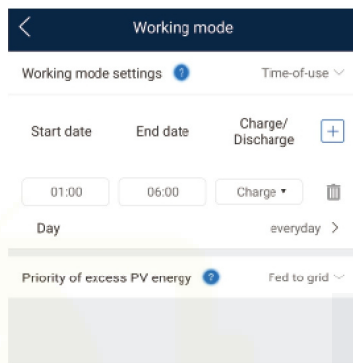

**Table 3-3** Time-of-use mode setting

| Parameter                         | Description   | Value Range   |
|-----------------------------------|---|---|
| Priority of excess PV energy      | <ul style="list-style-type: none"> <li>• <b>Charge:</b> When the generated PV energy is greater than the loads, excess PV energy is used to charge the batteries. After the maximum charge power is reached or the batteries are fully charged, the excess PV energy is fed to the grid.</li> <li>• <b>Fed to grid:</b> When the generated PV energy is greater than the loads, the excess PV energy is preferentially fed to the grid rather than used for battery charging. This setting is applicable to the scenario where the FIT is higher than the electricity price. Batteries are used only for backup power.</li> </ul> | <ul style="list-style-type: none"> <li>• Charge</li> <li>• Fed to grid</li> </ul>                 |
| Allowed charge power of grid (kW) | Indicates the maximum charge power allowed by the grid. The value is determined by the local grid company. If there is no requirement, the value is the maximum charge power of the ESS by default.   | <ul style="list-style-type: none"> <li>• [0, Maximum charge power allowed by the grid]</li> </ul> |

**Figure 3-6** Battery control parameter setting

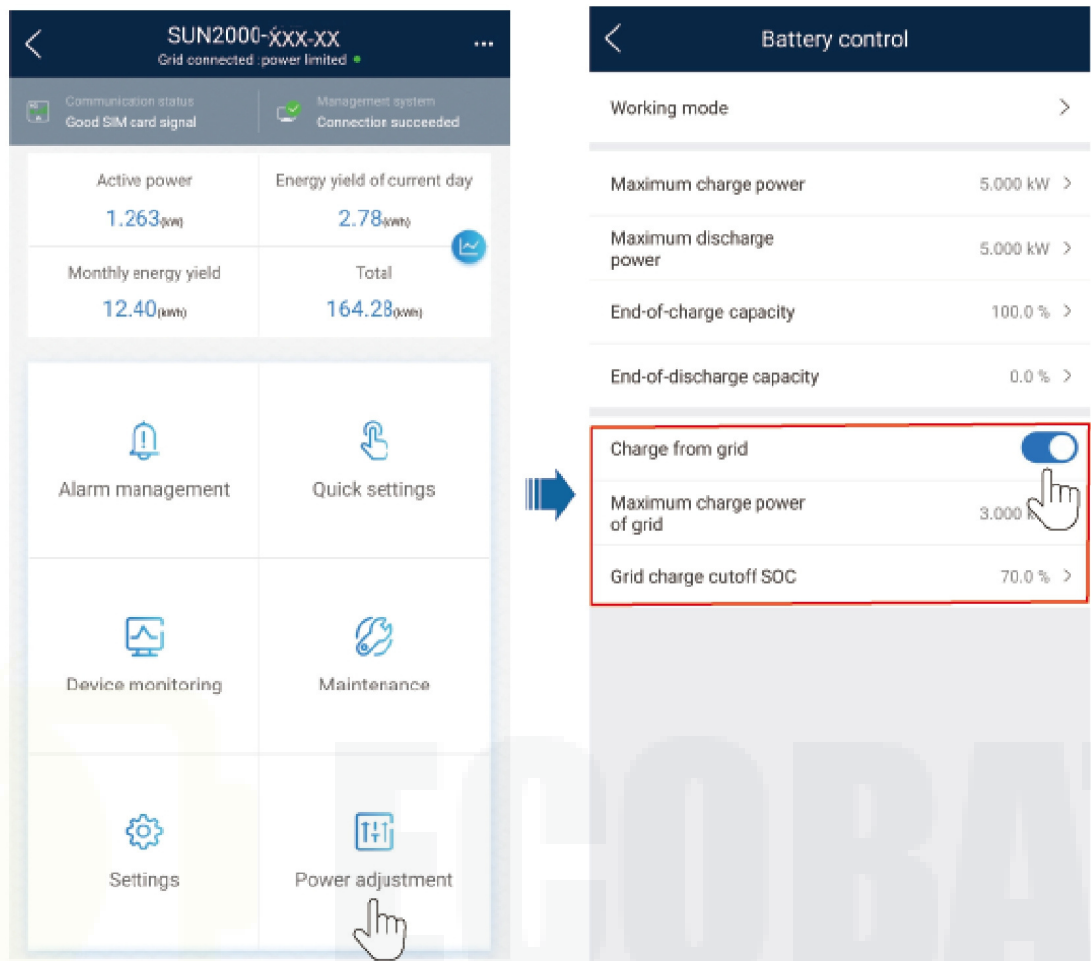

**Table 3-4** Time-of-use parameter setting

| Parameter              | Description  | Value Range   |
|------------------------|--|---|
| Charge from grid       | If <b>Charge from grid</b> function is disabled by default, comply with the grid charge requirements stipulated in local laws and regulations when this function is enabled. | <ul style="list-style-type: none"> <li>• Disable</li> <li>• Enable</li> </ul> |
| Grid charge cutoff SOC | Set the grid charge cutoff state of charge (SOC).  | [0, 100%]   |

### Example of the time-of-use electricity price

Examples of the time-of-use electricity price:

(1) Set the low-price time at night (00:00 to 03:00) as the charge time, and do not set the discharge time. The batteries can discharge in the remaining time segments and work in self-consumption mode. For example, when the sunlight is sufficient, the PV module outputs 8 kW power, the inverter outputs 5 kW power, the loads consume 4 kW power, and the batteries charge 1 kW power. When the sunlight becomes weak, the PV module outputs 4 kW power, the inverter outputs

2 kW power, the loads consume 4 kW power, and the batteries discharge to supply 1 kW power to the loads.

(2) Set power consumption peak hours (18:00 to 22:00) as the discharge time. During this time, the batteries discharge. During other periods, such as 00:00-18:00 and 22:00-24:00, surplus PV energy can be used to charge the batteries, and the batteries do not discharge. When the load power supply is insufficient, the grid supplies power to the loads. For example, when the sunlight is insufficient, the PV module outputs 3 kW power, the loads consume 5 kW power, and the grid supplies 2 kW power to the loads.

## Fully Fed to Grid

- This mode applies to the grid-tied scenario where PV energy is fully fed to the grid.
- This mode maximizes the PV energy for grid connection. When the generated PV energy in the daytime is greater than the maximum output capability of the inverter, the batteries are charged to store energy. When the PV energy is less than the maximum output capability of the inverter, batteries discharge to maximize the output energy of the inverter to the grid.
- In this mode, **Fully fed to grid** is selected. For details, see [6.3 Battery Commissioning](#).

### Example of fully fed to grid:

For example, when the PV modules generate 8 kW power, the SUN2000-5KTL inverter connects to the grid with the maximum output power of 5.5 kW, and the batteries charge 2.5 kW power. When the sunlight becomes weak, the PV modules generate 3 kW power, the batteries charge 2.5 kW power, and the inverter connects to the grid with the maximum output power of 5.5 kW.

## 3.2 Grid-tied and Off-grid ESS

The grid-tied and off-grid ESS is mainly used to supply power to loads when the grid is unstable and there are primary loads. The grid-tied and off-grid ESS switches the inverter to the grid-tied or off-grid state through the Backup Box. When the grid fails, the inverter switches to the off-grid state and supplies power to primary loads in backup mode. When the grid recovers, the inverter switches back to the grid-tied state.

### 3.2.1 Grid-tied and Off-grid ESS Networking

#### Networking 1: Inverter + Batteries

The grid-tied and off-grid ESS consists of the PV strings, LUNA2000 batteries, inverter, AC switch, load, Backup Box, PDU, and grid. The grid connection status of the inverter is switched by using the Backup Box.

**Figure 3-7** Basic networking of the parallel off-grid ESS (dashed boxes indicate optional components)

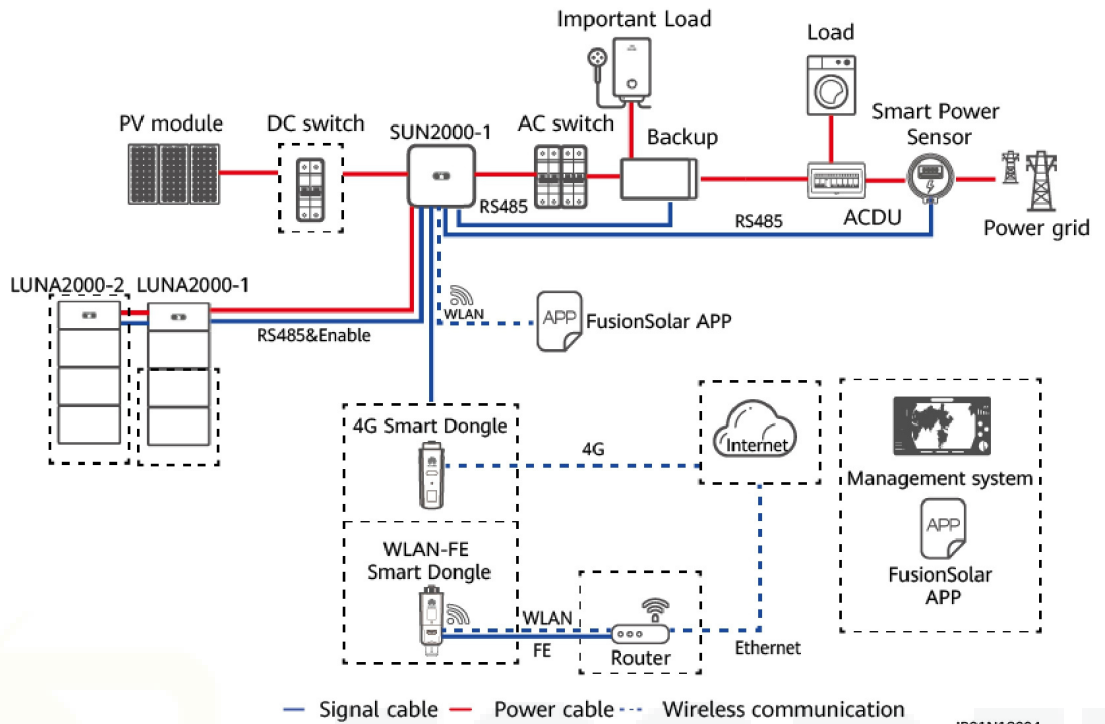

**NOTE**

The primary load power does not exceed the max off-grid output power of the Inverter.

**Networking 2: Inverter (with Batteries) + Inverter (Without Batteries)**

The grid-tied and off-grid ESS supports inverter cascading. One inverter connects to and manages the batteries. The Backup Box can connect to only one inverter output. The batteries, power meter, and Smart Dongle need to be connected to the same inverter.



**Figure 3-8** Inverter (with batteries) + inverter (without batteries) (dashed boxes indicate optional components)

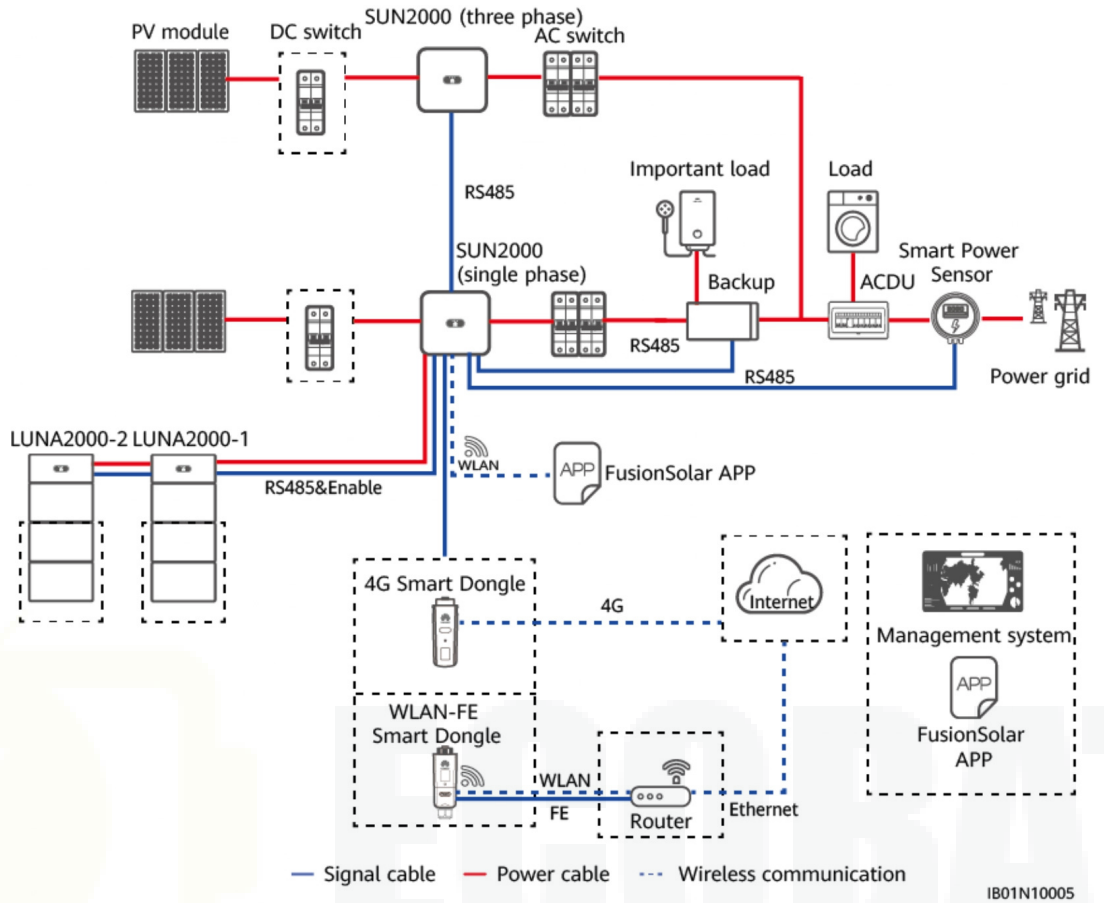

**NOTE**

When the grid charging function is enabled, the surplus power generated by the inverter without batteries can be used to charge the inverter connected to batteries.

**Networking 3: Inverter (with Batteries) + Inverter (with Batteries)**

A maximum of three inverters can be cascaded in the grid-tied and off-grid ESS. The batteries, power meter, and Smart Dongle need to be connected to the same inverter.



**Figure 3-9** Inverter (with batteries) + inverter (with batteries) (dashed boxes indicate optional components)

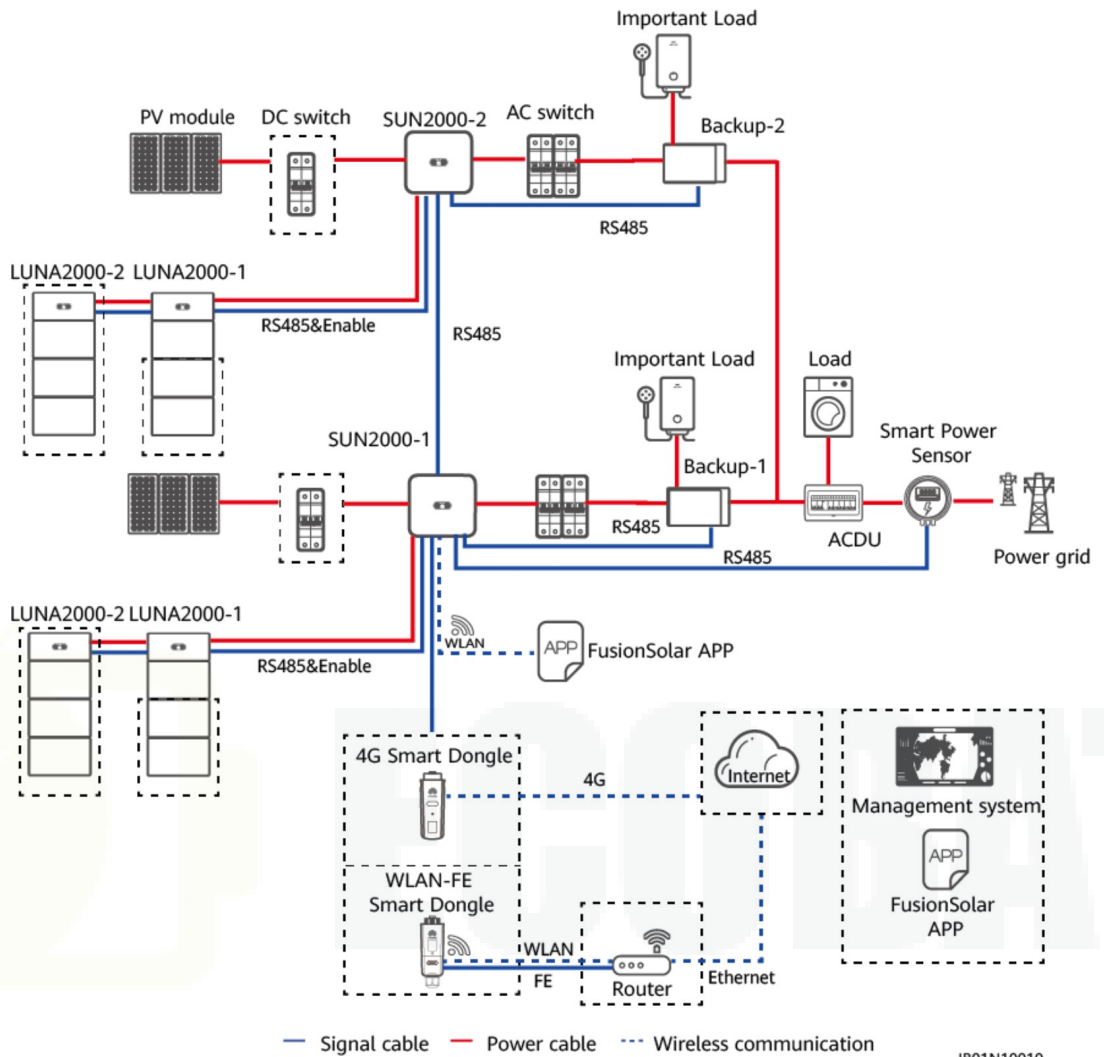

**NOTE**

The parameters of each battery need to be set separately. When the grid charging function is enabled, the surplus power generated by one inverter can be used to charge the other inverter.

**WARNING**

In the off-grid state, the output phases of cascaded inverters are different. The primary loads of the Backup Box connected to the inverters cannot be connected in parallel. The primary loads must be connected to different buses.

### 3.2.2 Setting the Grid-tied and Off-grid ESS Mode

The grid-tied and off-grid ESS switches the inverter to the grid connection status through the Backup Box. When the grid fails, the ESS supplies power to primary loads in backup mode. When the grid recovers, the ESS automatically switches back to the grid-tied mode.

- This mode can be used together with the self-consumption or time-of-use mode.
  - When the grid is normal, the self-consumption or time-of-use mode is used.
  - After the grid fails, the ESS switches to the power backup mode. The battery backup time depends on the battery SOC when the grid fails. (The battery SOC for power backup can be set based on customer requirements.)

### Enabling Off-grid Mode

On the home screen, choose **Settings > Feature parameters** and enable **Off-grid mode**.

**Figure 3-10** Backup power setting

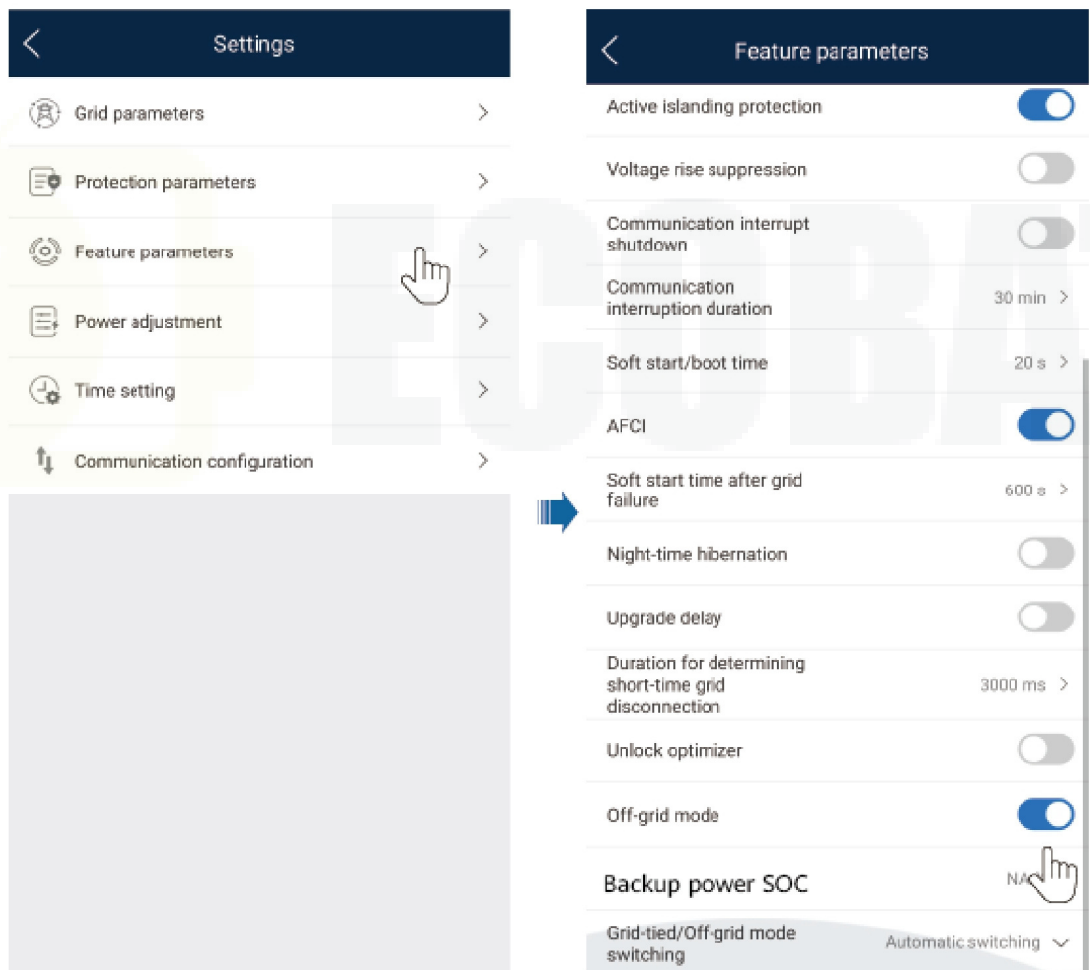

**Table 3-5** Grid-tied and off-grid parameter setting

| Parameter     | Description  | Value Range   |
|---------------|--|---|
| Off-grid mode | If this parameter is set to <b>Enable</b> , the ESS switches to the off-grid mode when the grid fails. | <ul style="list-style-type: none"> <li>• Enable</li> <li>• Disable</li> </ul> |

| Parameter                         | Description  | Value Range   |
|-----------------------------------|--|---|
| Backup power SOC                  | Sets the backup power SOC. In grid-tied mode, the battery does not discharge when it is discharged to the backup power SOC. When the grid fails, loads are powered in backup mode. | [0, 50%]  |
| Grid-tied/Off-grid mode switching | If this parameter is set to <b>Automatic switching</b> , the system switches to the off-grid mode when the grid fails, and switches to the grid-tied mode when the grid recovers.  | <ul style="list-style-type: none"> <li>• Automatic switching</li> <li>• Manual switching</li> </ul> |

## Setting a Working Mode

The grid-tied and off-grid ESS mode can be used together with the self-consumption or time-of-use mode. Enable **Off-grid mode** during site deployment. For details about how to set the self-consumption or time-of-use mode, see [3.1.2 Setting the Grid-tied ESS Mode](#).

## 3.3 Pure Off-grid ESS

The pure off-grid ESS is mainly used in the scenario where there is no grid and the system operates in pure off-grid mode. The pure off-grid ESS stores the generated PV energy in batteries and supplies power to loads when the PV energy is insufficient or there is no PV energy at night.

### 3.3.1 Pure Off-grid ESS Networking

The pure off-grid ESS consists of the PV strings, LUNA2000 batteries, inverter, AC switch, and load. In off-grid mode, PV strings and batteries must be configured.

The pure off-grid ESS supports only a single inverter and does not support parallel connection of inverters.

**Figure 3-11** Off-grid ESS (dashed boxes indicate optional components)

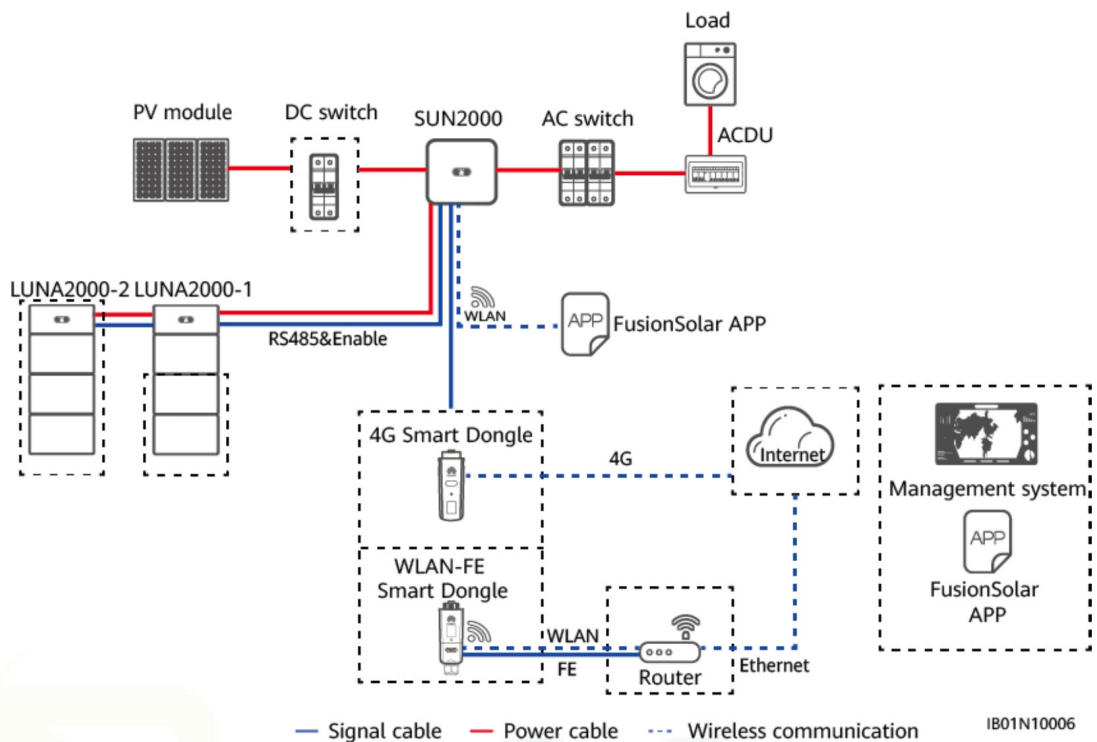

### 3.3.2 Setting the Pure Off-grid ESS Mode

The inverter works in off-grid mode. When the sunlight is sufficient, the ESS supplies power to loads and stores surplus PV energy in batteries. When the sunlight is insufficient or there is no sunlight, the batteries discharge to supply power to loads. By default, the charge cutoff capacity of Huawei LUNA2000 batteries is 100% and the discharge cutoff capacity is 0%. For details about how to change the charge or discharge cutoff capacity, see [6.3 Battery Commissioning](#). In off-grid mode, you need to set the off-grid power grid code on the **Quick setting** screen.

**Figure 3-12** Setting the off-grid power grid code

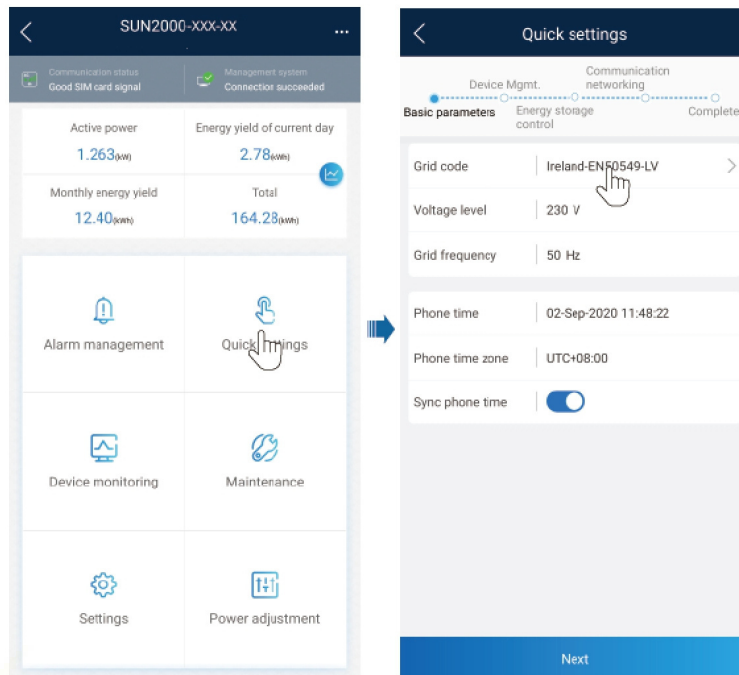

**NOTE**

If the mains is unavailable, you need to set the off-grid power grid code. In off-grid mode, the battery must be configured.

The battery does not discharge when it is discharged to the SOC. When sunlight is available on the next day, the battery starts to supply power to loads after being charged to a certain amount of electricity.

# 4 System Installation

## 4.1 Checking Before the Installation

### Checking the Outer Packing

Before unpacking the battery, check the outer packing for damage, such as holes and cracks, and check the battery model. If any damage is found or the battery model is not what you requested, do not unpack the product and contact your dealer as soon as possible.

### Checking Deliverables

After unpacking the battery, check that the deliverables are intact and complete, and free from any obvious damage. If any item is missing or damaged, contact your dealer.







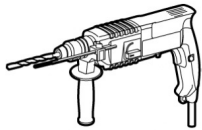
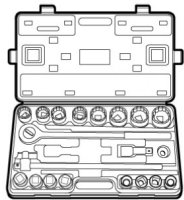
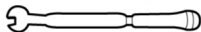



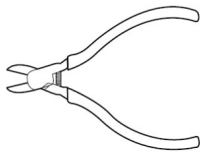
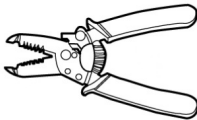
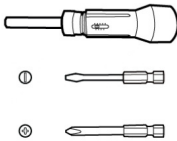

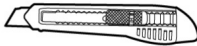
 **NOTE**

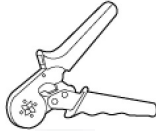

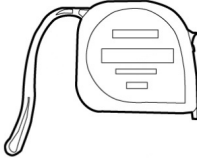

For details about the number of deliverables delivered with the battery, see the *Packing List* in the packing case.

## 4.2 Preparing Tools and Instruments

| Type         | Tools and Instruments  |  |  |
|--------------|--|--|--|
| Installation |  <p>Hammer drill (with a drill bit of 8 mm)</p> |  <p>Torque socket wrench</p> |  <p>Torque wrench</p> |

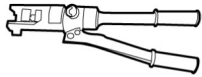
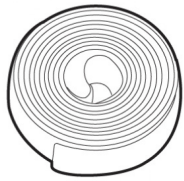
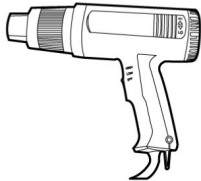

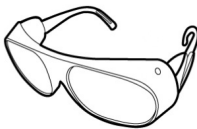
| Type | Tools and Instruments  |  |  |
|------|--|--|--|
|      | <br>Diagonal pliers                     | <br>Wire strippers           | <br>Torque screwdriver  |
|      | <br>Rubber mallet                       | <br>Utility knife            | <br>Cable cutter  |
|      | <br>Crimping tool (model: PV-CZM-22100) | <br>Cord end terminal crimper | <br>Disassembly and Assembly Tool (model: PV-MS-HZ open-end wrench) |
|      | <br>Cable tie                         | <br>Vacuum cleaner          | <br>Multimeter (DC voltage measurement range $\geq 600$ V DC)     |
|      | <br>Marker                            | <br>Steel measuring tape   | <br>Level   |

| Type                                | Tools and Instruments   |  |   |
|-------------------------------------|---|--|---|
|                                     | <br>Hydraulic pliers | <br>Heat-shrink tubing | <br>Heat gun       |
| Personal protective equipment (PPE) | <br>Safety gloves    | <br>Safety goggles     | <br>Anti-dust mask |
|                                     | <br>Safety boots     | -  | -   |

## 4.3 Determining the Installation Position

### Basic Requirements

- Do not install the battery in a position where it is easy to touch because the temperature of the chassis and heat sink is high when the battery is running.
- Do not install the battery in areas with flammable or explosive materials.
- Do not install the battery outdoors in salt-affected areas because it may corrode and cause fires. A salt-affected area refers to the region within 500 meters from the coast or prone to sea breeze. The regions prone to sea breeze vary with weather conditions (such as typhoons and monsoons) or terrains (such as dams and hills).
- Do not install the battery in a position where children can touch it.

### Installation Angle Requirement

The battery can be floor-mounted and wall-mounted. The installation angle requirement is as follow:

- Do not install the battery at forward tilted, back tilted, side tilted, horizontal, or upside down positions.

## Installation Space Requirements

- Reserve sufficient clearance around the battery to ensure sufficient space for installation and heat dissipation.

Figure 4-1 Installation space

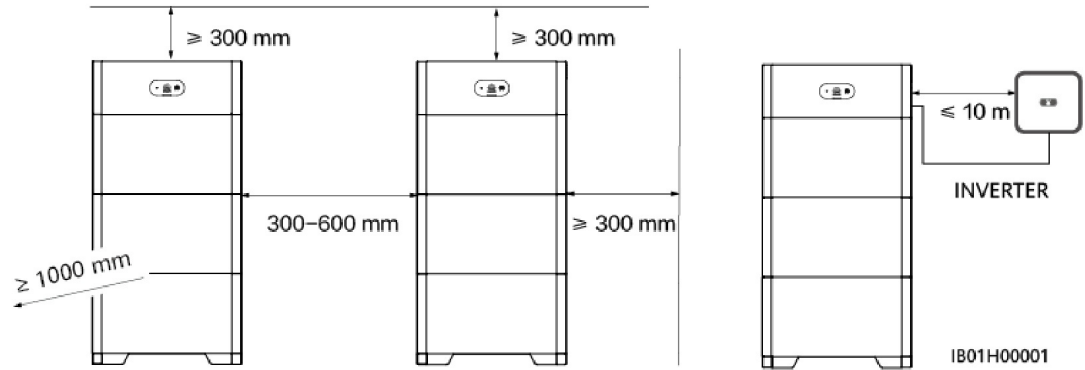

## 4.4 Equipment Installation

### 4.4.1 Floor-Mounted Installation

#### Installation Precautions

Figure 4-2 shows the dimensions of mounting holes for a battery.

**Figure 4-2** Floor-mounted installation dimensions

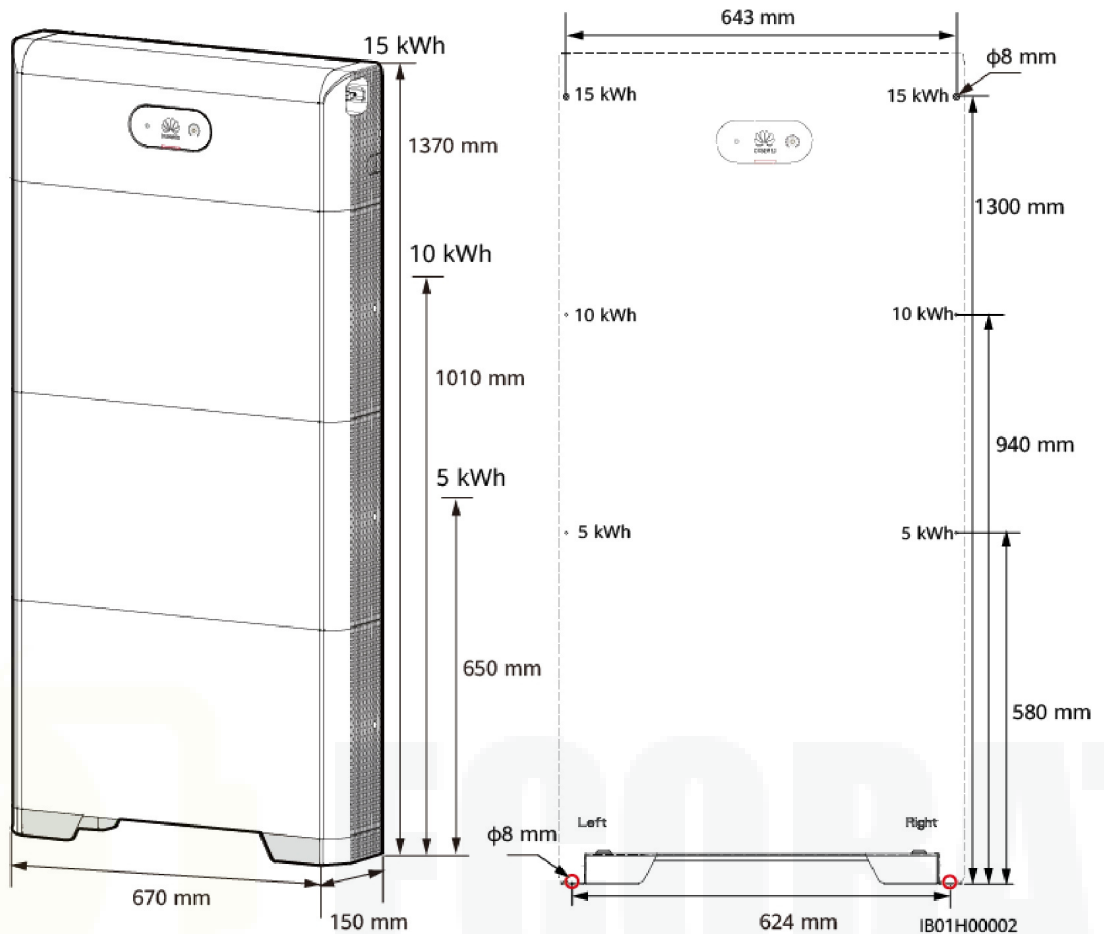

## Procedure

- Step 1** Align the floor support with the wall surface and keep the support 10 mm to 15 mm away from the wall surface. Level the hole positions using a level, and mark the hole positions for installing the floor support using a marker. Align the marking-off template with the surface of the floor mounting kit, determine the drilling hole positions on the wall for securing the power control module, and mark the positions using a marker.
- Step 2** Install the floor support.

### DANGER

When drilling holes, avoid the water pipes and power cables buried in the wall.

### NOTE

M6x60 expansion bolts delivered with the battery are used to install the floor support and power control module. If the length and quantity of the bolts do not meet installation requirements, prepare M6 stainless steel expansion bolts by yourself.

**Figure 4-3** M6 expansion bolt structure diagram

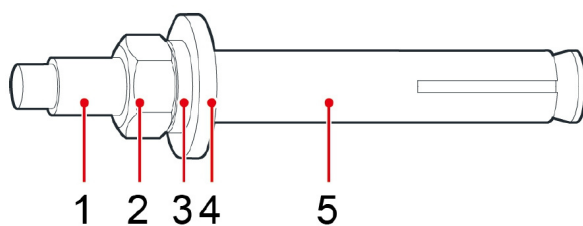

IS05W00018

- |                 |                      |                   |
|-----------------|----------------------|-------------------|
| (1) Bolt        | (2) Nut              | (3) Spring washer |
| (4) Flat washer | (5) Expansion sleeve |                   |

#### NOTICE

- To prevent dust inhalation or contact with eyes, wear safety goggles and an anti-dust mask when drilling holes.
- Wipe away any dust in or around the holes and measure the hole distances. If the holes are inaccurately positioned, drill holes again.
- Level the head of the expansion sleeve with the concrete wall or floor after removing the nut, spring washer, and flat washer. Otherwise, the mounting kit will not be securely installed on the wall or ground.
- Loosen the nut, spring washer, and flat washer of the expansion bolt at the bottom.

Figure 4-4 Installing expansion bolts

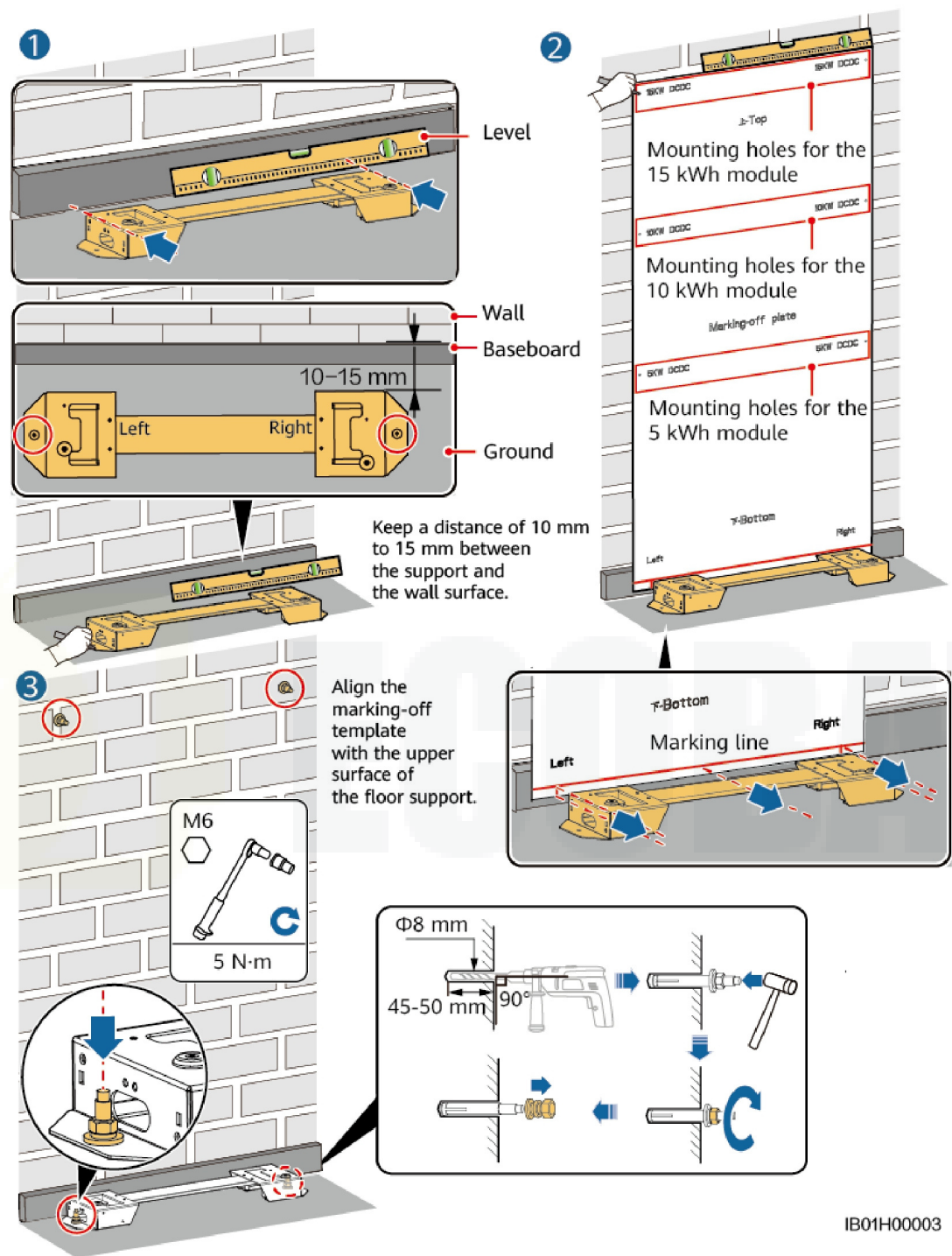

IB01H00003

**Step 3** Place the first battery expansion module on the floor support, install the connecting pieces on both sides, and tighten the four screws. Install the remaining battery expansion modules and power control module from bottom to top.

**⚠ WARNING**

After installing a module, install and tighten the connecting pieces and screws on the left and right sides of the module, and then install the next module.



**Figure 4-5** Installing the battery expansion modules and power control module

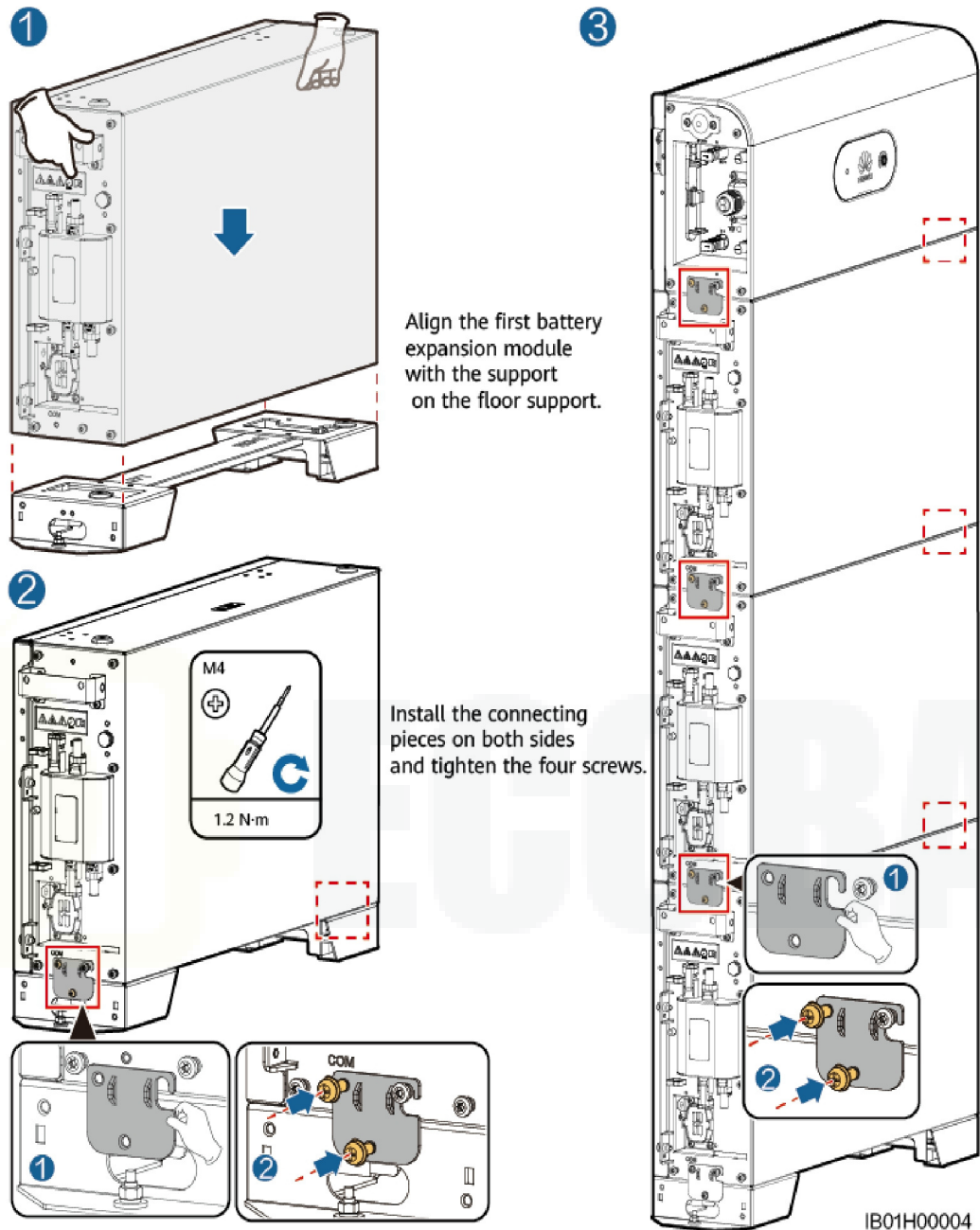

Install the remaining battery expansion modules and power control module from bottom to top.

**Step 4** Secure the power control module to the wall.

**⚠ WARNING**

The power control module must be fixed on the wall to prevent it from falling down.

**Figure 4-6** Fixing the power control module

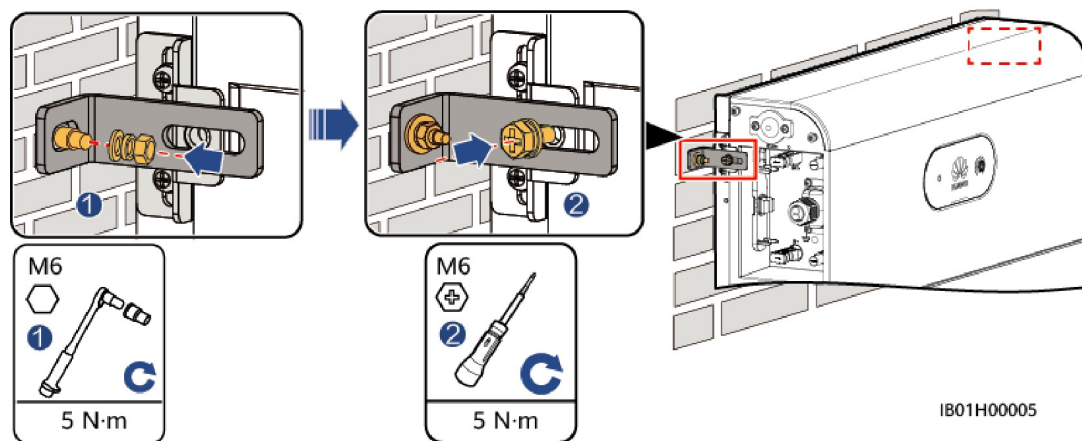

IB01H00005

-----End

## 4.4.2 Wall-Mounted Installation

### Installation Precautions

**Figure 4-7** shows the dimensions of mounting holes for the battery on the wall.

**Figure 4-7** Wall-mounted installation dimensions

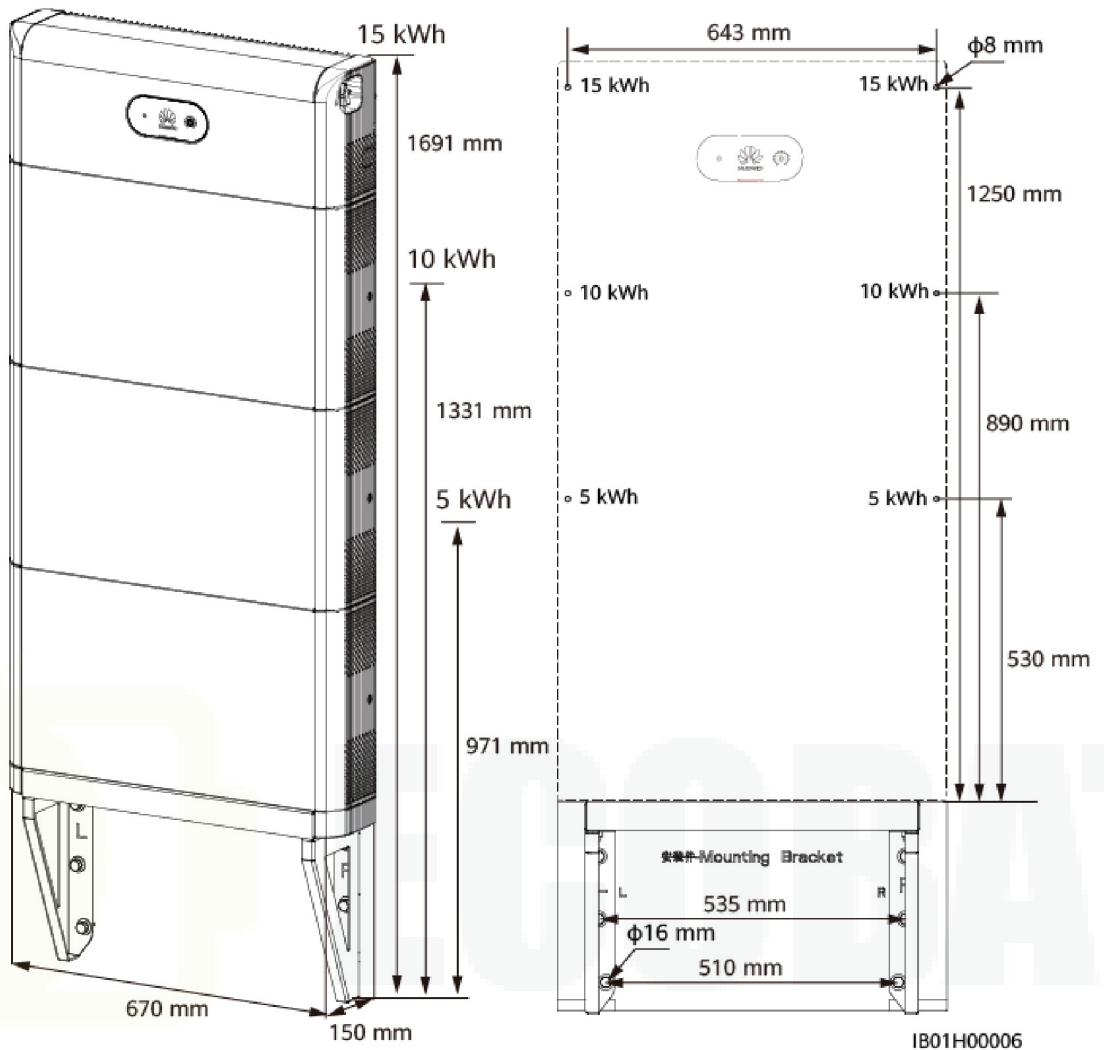

## Procedure

- Step 1** Determine the positions for drilling holes using the marking-off template. Level the positions of mounting holes using a level, and mark the positions with a marker.
- Step 2** Install the mounting kit.

### DANGER

When drilling holes, avoid the water pipes and power cables buried in the wall.

### NOTE

M12x60 expansion bolts delivered with the battery are used to fix the wall mounting support. If the length and quantity of the bolts do not meet installation requirements, prepare M12 stainless steel expansion bolts by yourself.

M6x60 expansion bolts delivered with the battery are used to fix the power control module. If the length and quantity of the bolts do not meet installation requirements, prepare M6 stainless steel expansion bolts by yourself.

Figure 4-8 Wall-mounted installation

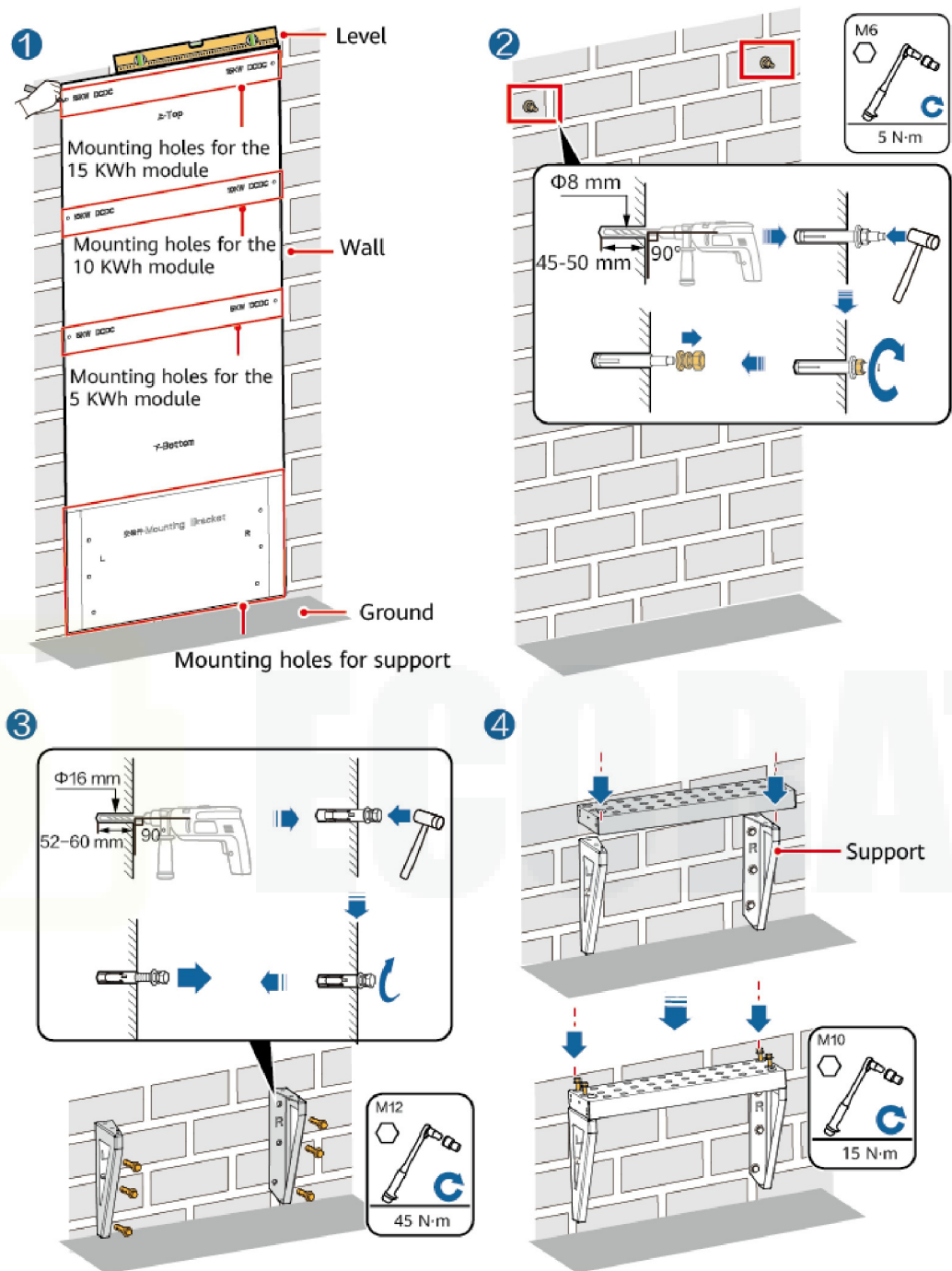

IB01H00007

**Step 3** Place the first battery expansion module on the wall-mounted support, install the left and right connective pieces, and install the second battery expansion module, third battery expansion module, and power control module from bottom to top.

**WARNING**

After installing a module, install and tighten the connecting pieces and screws on the left and right sides of the module, and then install the next module.

# 5 Electrical Connection

---

## Precautions

---

 **DANGER**

Before connecting cables, ensure that the DC switch on the battery and all the switches connected to the battery are set to OFF. Otherwise, the high voltage of the battery may result in electric shocks.

---

---

 **WARNING**

- The equipment damage caused by incorrect cable connections is not covered under any warranty.
  - Only certified electricians are allowed to connect cables.
  - Operation personnel must wear proper PPE when connecting cables.
- 

 **NOTE**

The cable colors shown in the electrical connection diagrams provided in this chapter are for reference only. Select cables in accordance with local cable specifications (green-and-yellow cables are only used for PE).

## 5.1 Preparing Cables

Figure 5-1 Battery cable connections

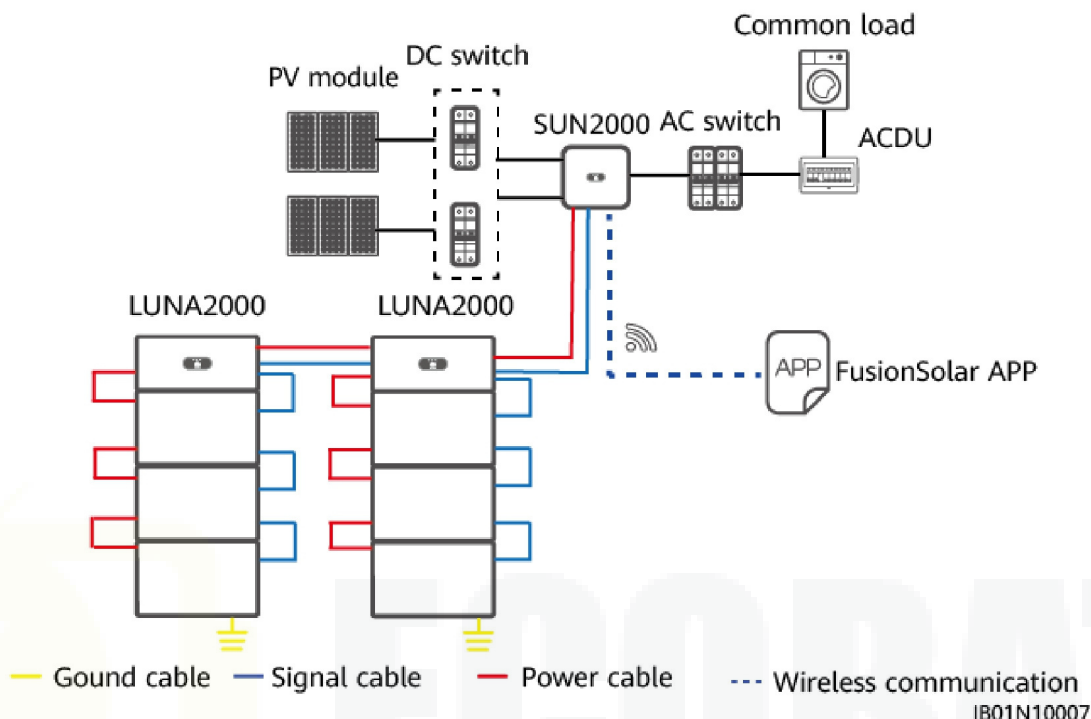

Table 5-1 Cables prepared by the customer

| No. | Cable   | Type  | Recommended Specifications   | Source                   |
|-----|---|---|--|--------------------------|
| 1   | DC input power cable (inverter to battery and battery to battery) | Common outdoor PV cable in the industry       | <ul style="list-style-type: none"> <li>Conductor cross-sectional area: 4–6 mm<sup>2</sup></li> <li>Cable outer diameter: 5.5–9 mm</li> </ul>       | Prepared by the customer |
| 2   | Signal cable (inverter to battery and battery to battery)         | Outdoor shielded twisted pair cable (8 cores) | <ul style="list-style-type: none"> <li>Conductor cross-sectional area: 0.20–0.35 mm<sup>2</sup></li> <li>Cable outer diameter: 6.2–7 mm</li> </ul> | Prepared by the customer |
| 3   | Ground cable  | Single-core outdoor copper cable              | <ul style="list-style-type: none"> <li>10 mm<sup>2</sup></li> </ul>  | Prepared by the customer |



**Table 5-2** Cables delivered with the battery

| No. | Cable   | Type                                    | Source                     |
|-----|---|---|----------------------------|
| 1   | DC input power cable (power control module to battery expansion module) | Common outdoor PV cable in the industry | Delivered with the product |
| 2   | Signal cable (power control module to battery expansion module)         | Outdoor shielded twisted pair cable     | Delivered with the product |
| 3   | Ground cable  | Single-core outdoor copper cable        | Delivered with the product |

 **NOTE**

- The minimum cable diameter must comply with local cable standards.
- The factors that affect cable selection include the rated current, cable type, routing mode, ambient temperature, and maximum expected line loss.

## 5.2 Internal Electrical Connections of the Battery

 **NOTE**

Internal cables are delivered with the battery. For details, see the Packing List in the packing case.

### 5.2.1 Installing an Internal Ground Cable

#### Precautions



Ensure that the PE cable is securely connected. Otherwise, electric shocks may occur.

 NOTE

It is recommended that silica gel or paint be used around the ground terminal after the PE cable is connected.

- Step 1** Connect the PE cable to the battery power control modules and battery expansion modules.

**Figure 5-2** Connecting the internal PE cable

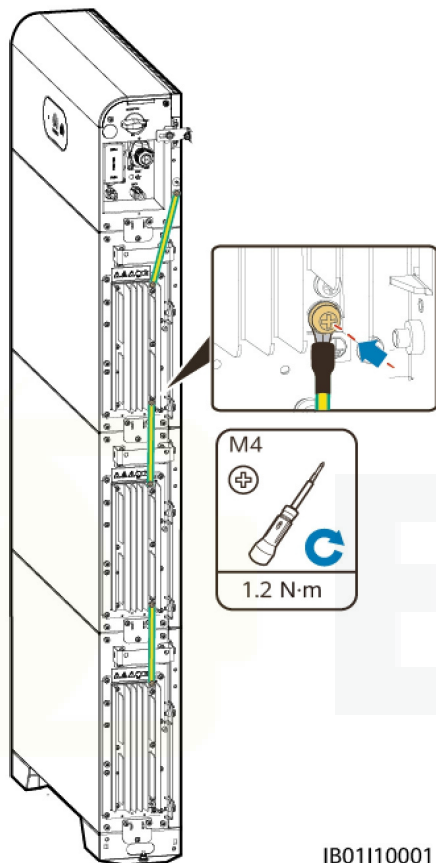

----End

## 5.2.2 Installing Internal DC Terminals

- Step 1** Insert the positive and negative connectors delivered with the battery into the positive and negative battery cascading terminals (B+ and B-).

Figure 5-3 DC power cable connection inside the battery

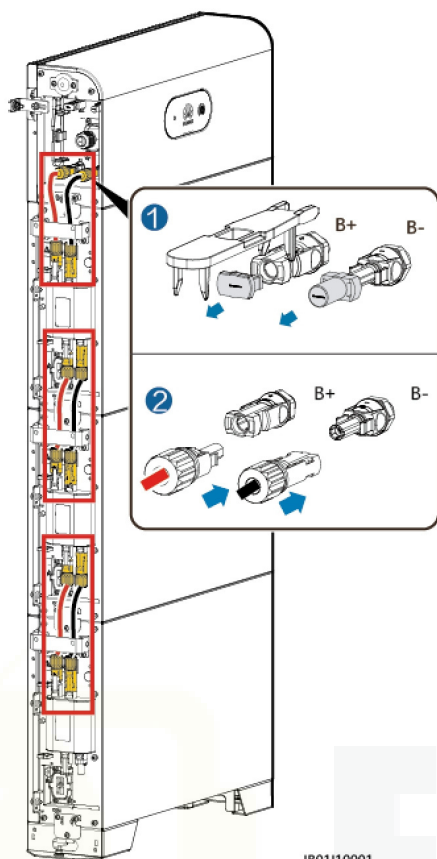

**NOTE**

The DC terminals between the power control module and the battery expansion modules use the DC connection cable (Amphenol terminal) delivered with the battery.

**NOTICE**

After the positive and negative connectors snap into place, pull the DC input power cables back to ensure that they are connected securely.

----End

### 5.2.3 Connecting Internal Signal Cables

#### Connecting Signal Cables Between the Power Control Module and Battery Expansion Modules

Connect the communications terminals of the power control module and battery expansion modules in sequence and secure them using cable clips.

**Figure 5-4** Signal cable connections between the power module and battery modules

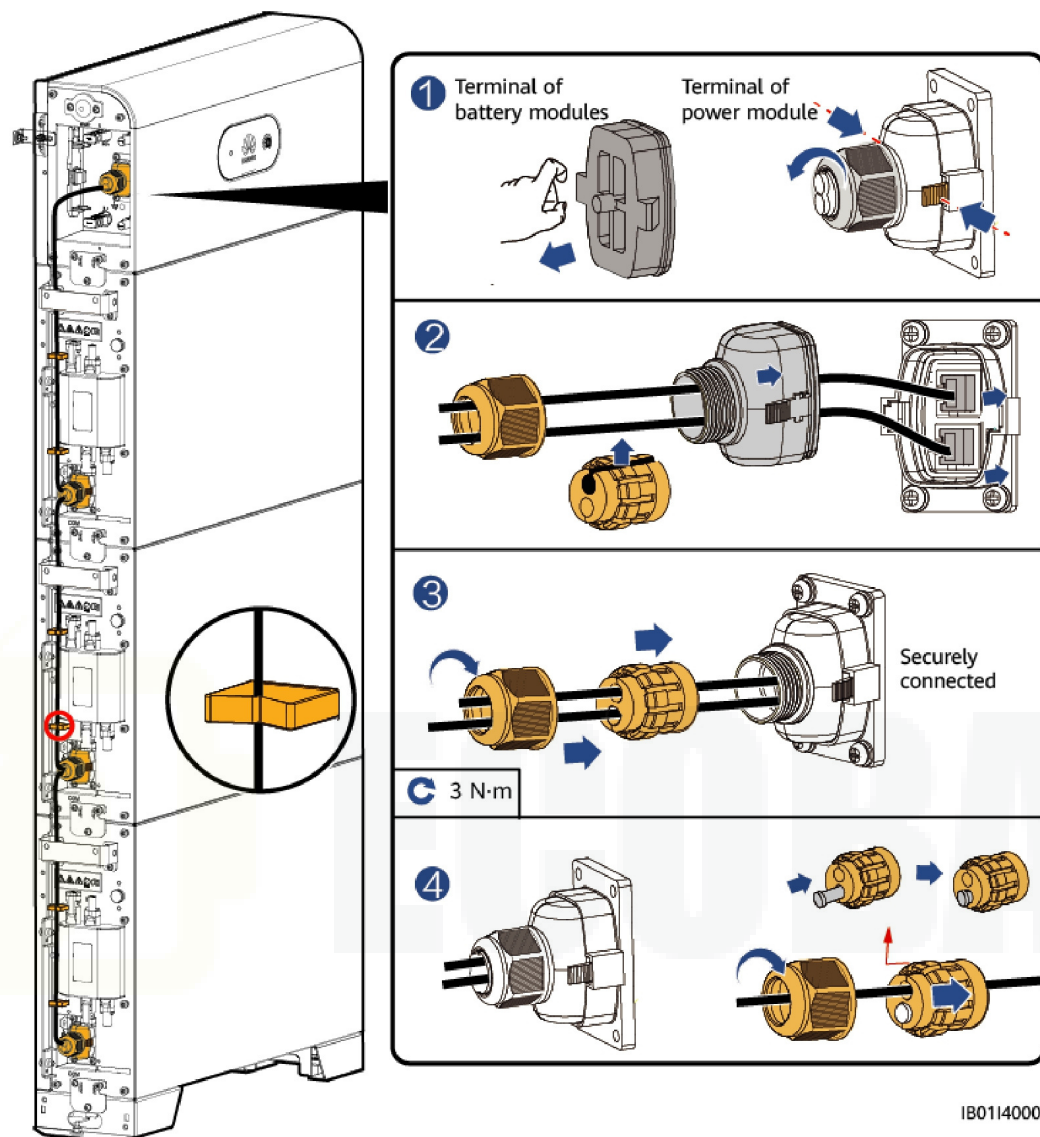

**NOTE**

When a communications terminal is connected to a single network cable, a waterproof rubber plug must be installed.

## 5.3 External Electrical Connections of the Battery

### Routing Cables Out of the Cable Hole

Cut a cable hole based on the cabling mode, and route external cables through the cable hole.

**Figure 5-5** Routing cables out of the cable hole

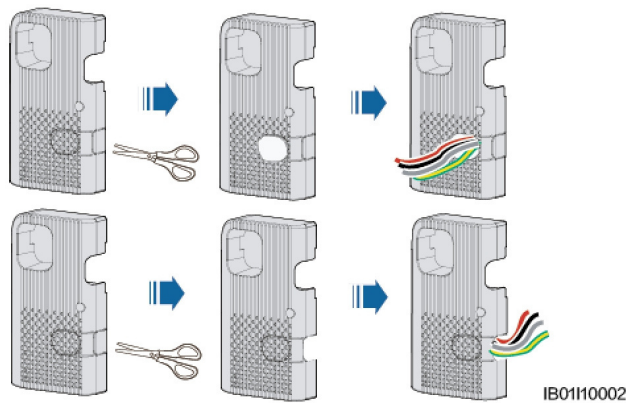

**NOTICE**

Before connecting external cables, route the cables through the cable hole to avoid disconnecting after installation.

### 5.3.1 Installing a PE Cable

#### Precautions

**⚠ DANGER**

Ensure that the PE cable is securely connected. Otherwise, electric shocks may occur.

**📖 NOTE**

It is recommended that silica gel or paint be used around the ground terminal after the PE cable is connected.

#### Procedure

**Step 1** Crimp an OT terminal.

**NOTICE**

- Avoid scratching the core wire when stripping a cable.
- The cavity formed after the conductor crimp strip of the OT terminal is crimped must wrap the core wires completely. The core wires must contact the OT terminal closely.
- Wrap the wire crimping area with heat shrink tubing or insulation tape. The heat shrink tubing is used as an example.
- When using a heat gun, protect the equipment from being scorched.

**Figure 5-6** Crimping an OT terminal

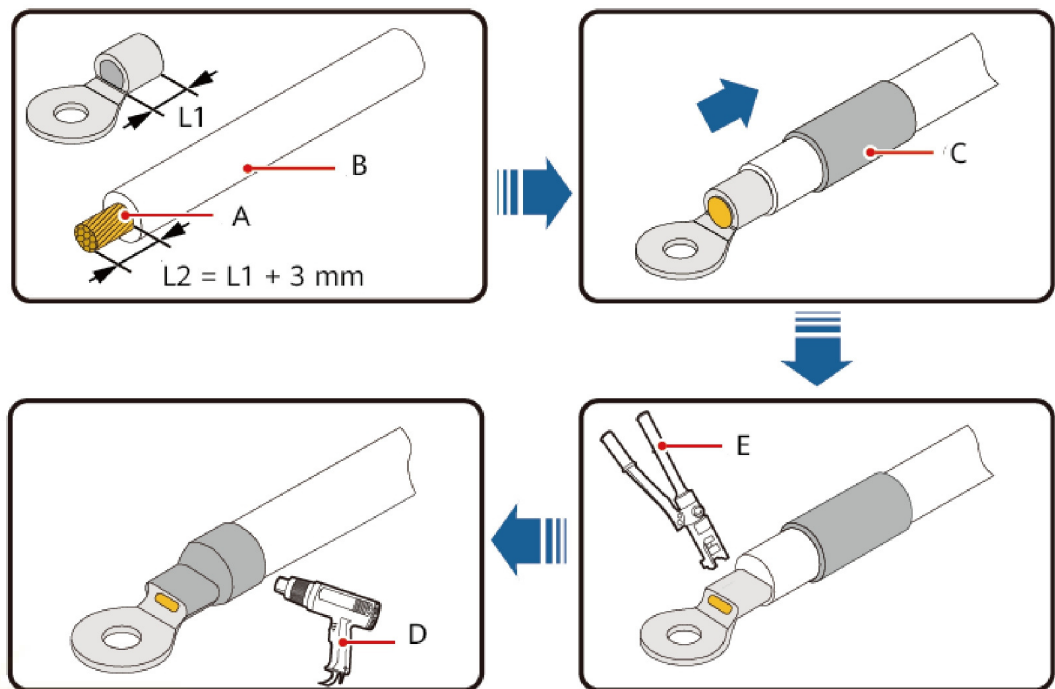

IS05200001

(A) Core wire

(B) Insulation layer

(C) Heat shrink tubing

(D) Heat gun

(E) Hydraulic pliers

**Step 2** Connect the ground point of the power control module to the external ground point.

**Figure 5-7** Grounding the PE cable

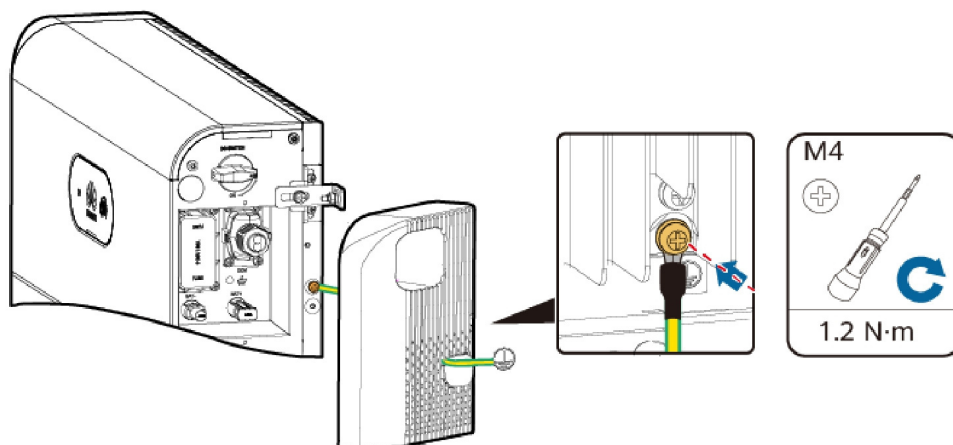

IB01I50001

**NOTE**

It is recommended that silica gel or paint be used around the ground terminal after the PE cable is connected.

----End



## 5.3.2 Installing DC Input Power Cables

### Connect DC input power cables to the inverter

Insert the positive and negative battery connectors (Staubli) into the corresponding DC input terminals (BAT+ and BAT-).

 **NOTE**

The DC input terminals (BAT+ and BAT-) on the left and right sides of the battery are the same.

**Step 1** Assemble DC connectors.

**Figure 5-8** Assembling DC connectors

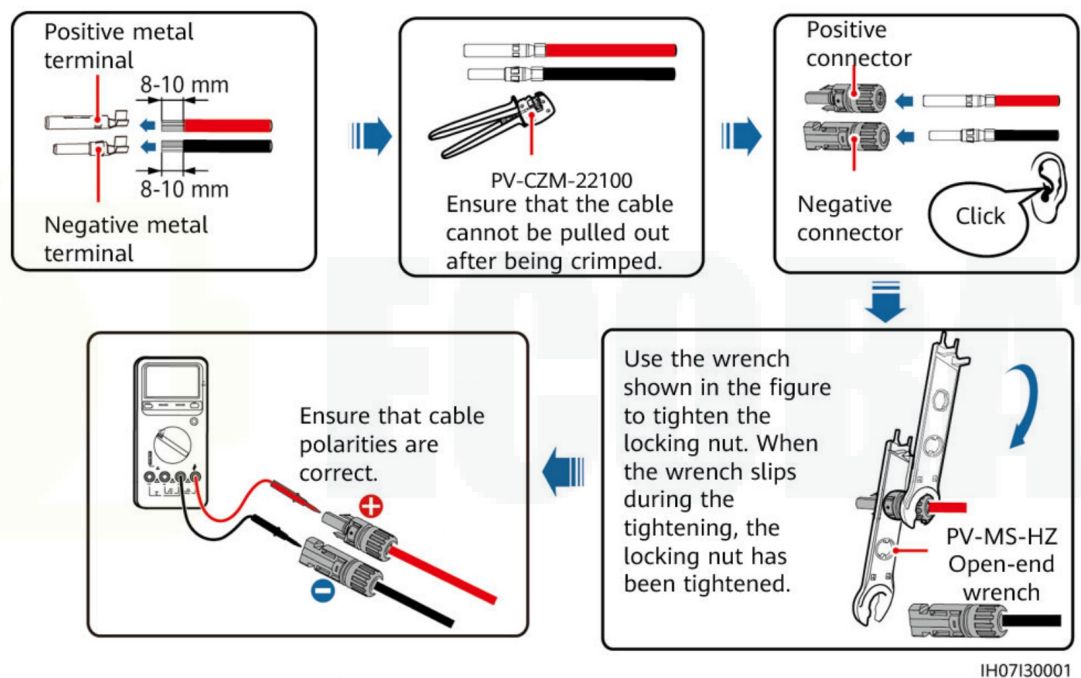

 **CAUTION**

Use Staubli MC4 positive and negative metal terminals and DC connectors. Using incompatible positive and negative metal terminals and DC connectors may result in serious consequences. The caused equipment damage is not covered under any warranty or service agreement.

**NOTICE**

- Keep the DC input BAT+ cable and BAT- cable close to each other.
- Cables with high rigidity, such as armored cables, are not recommended as DC input power cables to avoid cable folding.
- Before assembling DC connectors, label the cable polarities correctly to ensure correct cable connections.
- After crimping the positive and negative metal terminals, pull the DC input power cables back to ensure that they are connected securely.
- Insert the crimped metal terminals of the positive and negative power cables into the appropriate positive and negative connectors. Then pull back the DC input power cables to ensure that they are connected securely.

**Step 2** Insert the positive and negative connectors into the battery terminals (BAT+ and BAT-) on the switch and connect the other end to the cascaded battery.

**Figure 5-9** Connecting battery cables

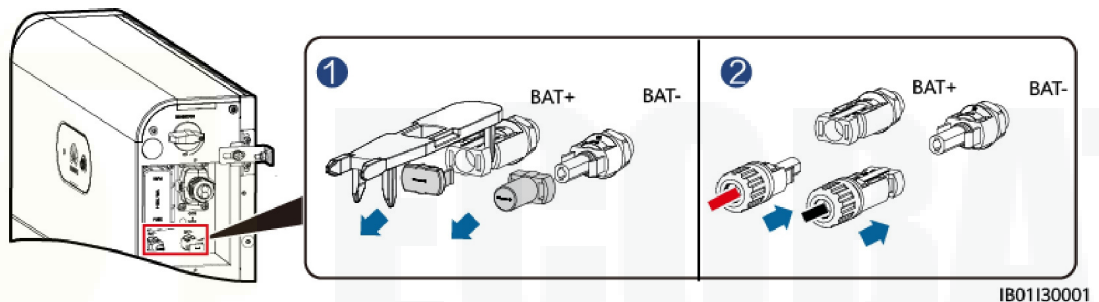

----End

### 5.3.3 Installing a Signal Cable

#### Connecting the Signal Cable between the Power Control Module and the Inverter

**NOTICE**

When laying out a signal cable, separate it from power cables and keep it away from strong interference sources to prevent communication interruption.

The COM port definitions on both sides of the power control module are the same. It is recommended that the COM port on the switch side be connected to the inverter and the COM port on the other side be connected to the cascaded battery.

**Figure 5-10** Signal cable ports

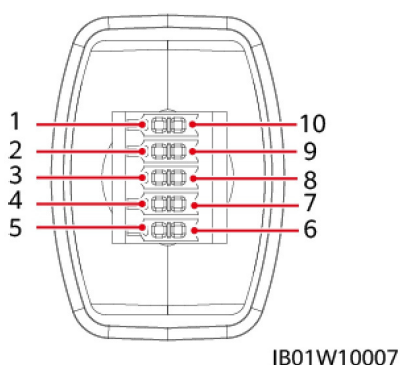

**Table 5-3** COM port definition

| No. | Label   | Definition                         | Description   |
|-----|---------|------------------------------------|---|
| 1   | PE      | Shield layer grounding             | Shield layer grounding  |
| 2   | Enable- | Enable signal GND                  | Connects to the enable signal GND of the inverter.              |
| 3   | Enable+ | Enable signal+                     | Connects to the positive enable signal of the inverter.         |
| 4   | 485A1   | RS485A, RS485 differential signal+ | Connects to the RS485 signal port of the inverter.              |
| 5   | 485A2   | RS485A, RS485 differential signal+ |   |
| 6   | 485B1   | RS485B, RS485 differential signal- | Connects to the RS485 signal port of the inverter.              |
| 7   | 485B2   | RS485B, RS485 differential signal- |   |
| 8   | CANL    | Extended CAN bus port              | Used for signal cable cascading in battery cascading scenarios. |
| 9   | CANH    | Extended CAN bus port              | Used for signal cable cascading in battery cascading scenarios. |
| 10  | PE      | Shield layer grounding             | Shield layer grounding  |

## Terminals

### NOTE

Identify the signal terminal pins according to the following figures, and connect cables according to [Table 5-3](#). When you insert the communications terminal of the power control module, the silk screens on the two sides of the communications port are different. Insert the communications terminal according to the following figures.

Figure 5-11 Inserting the terminal

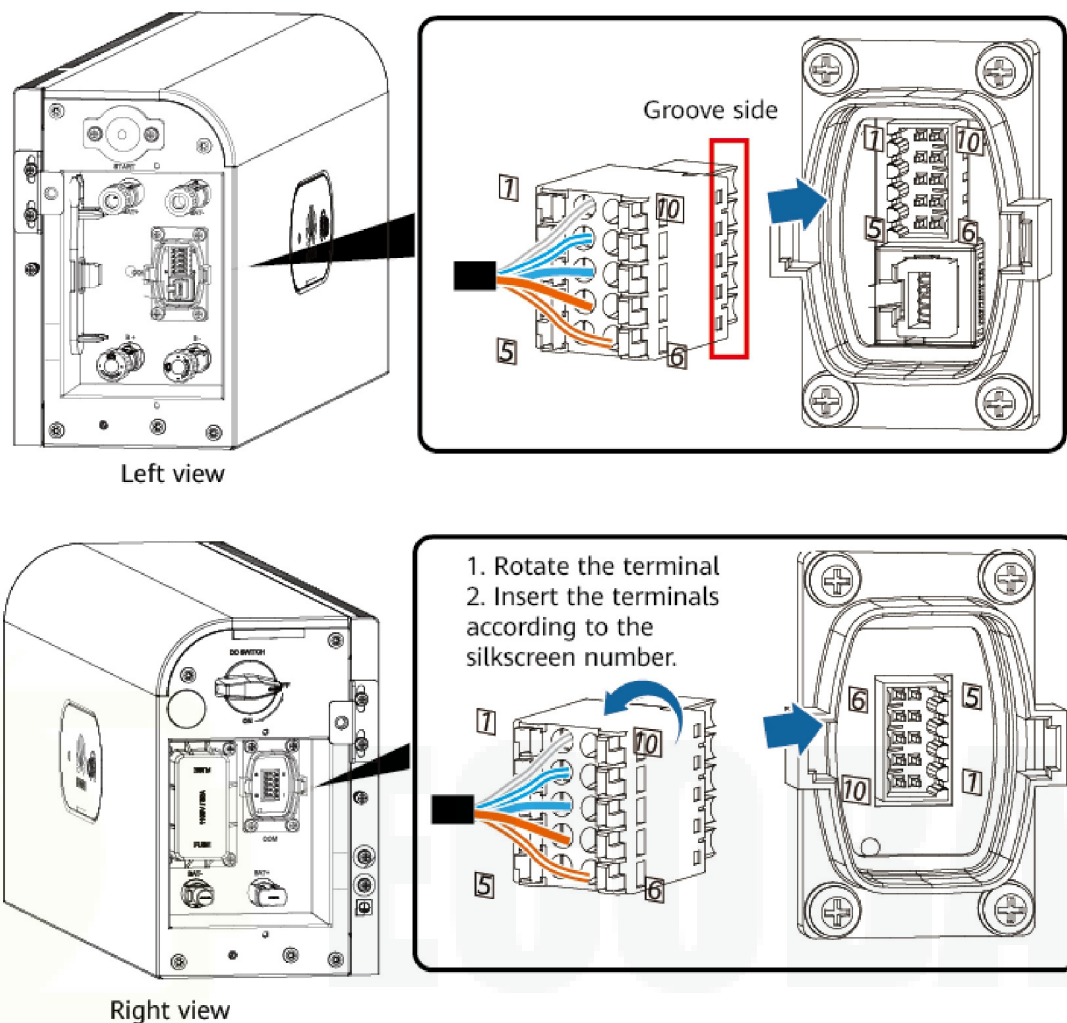

## Connecting a Signal Cable

Prepare signal cable terminals for connecting to the inverter.

Figure 5-12 Connecting inverter terminals

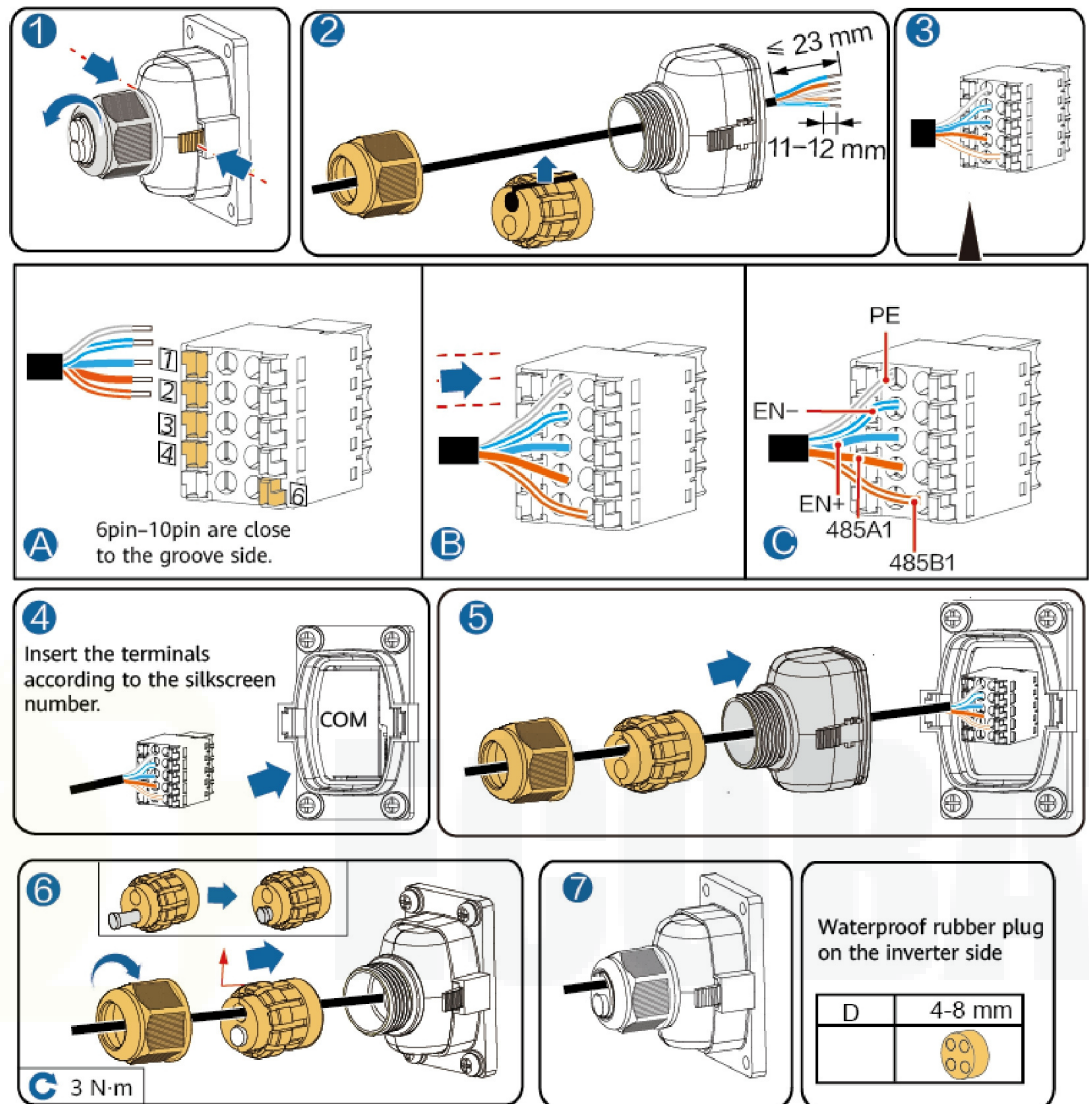

IB01140002

## 5.4 (Optional) Cascading Batteries

### Battery Cascading Cable Connection

Figure 5-13 Battery cascading cable connection

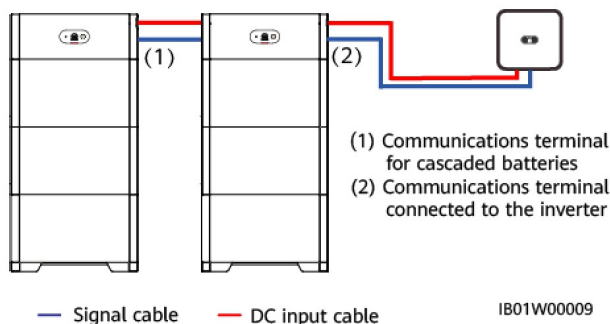



## Connecting Cascading DC Input Power Cables (Cascading)

Connect the DC input terminals (BAT+ and BAT-) between the power control module by referring to [5.3.2 Installing DC Input Power Cables](#).

### Terminals

#### NOTE

Identify the signal terminal pins according to the following figures, and connect cables according to [Table 5-3](#). When you insert the communications terminal of the power control module, the silk screens on the two sides of the communications port are different. Insert the communications terminal according to the following figures.

Figure 5-14 Inserting the terminal

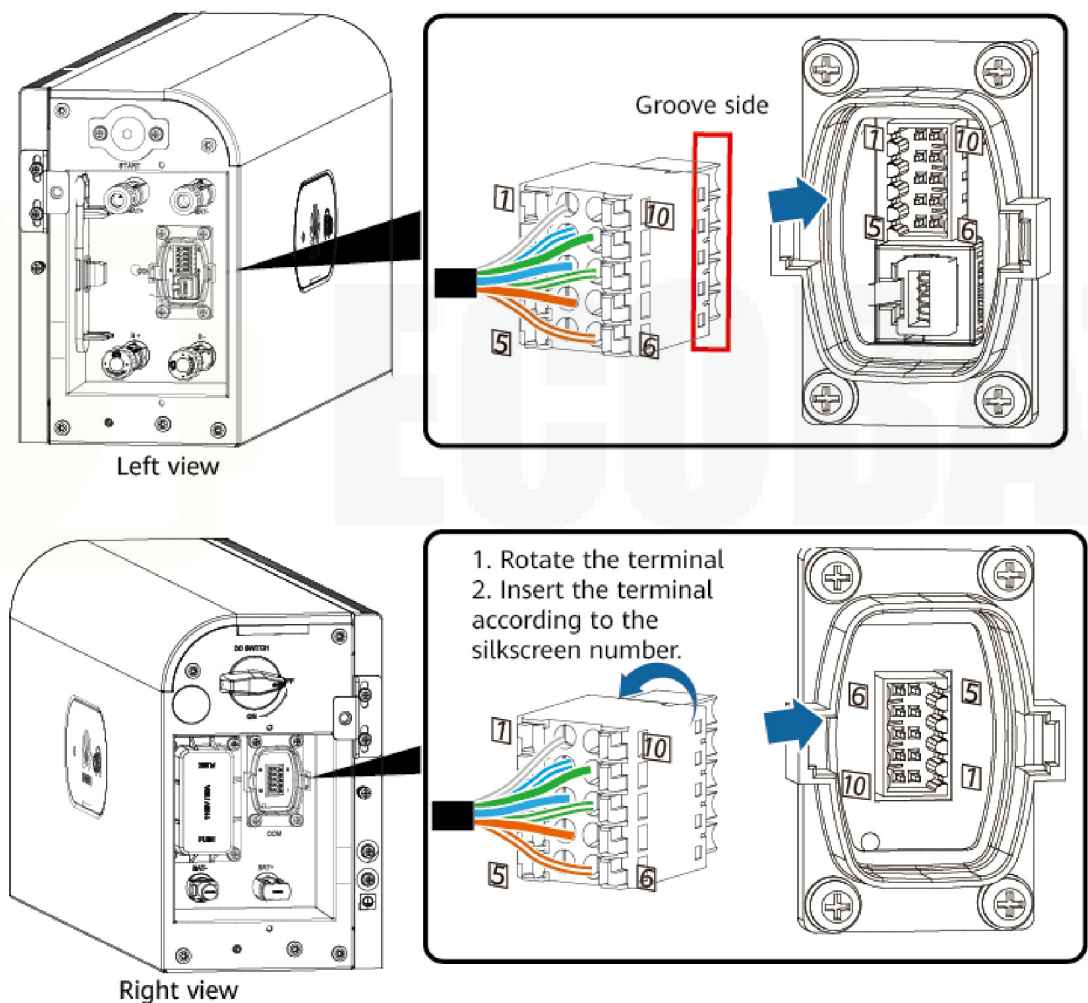

## Connecting a Signal Cable (Cascading)

Prepare a signal cable terminal for connecting the power control module.



**Figure 5-15** Cascading communication terminal

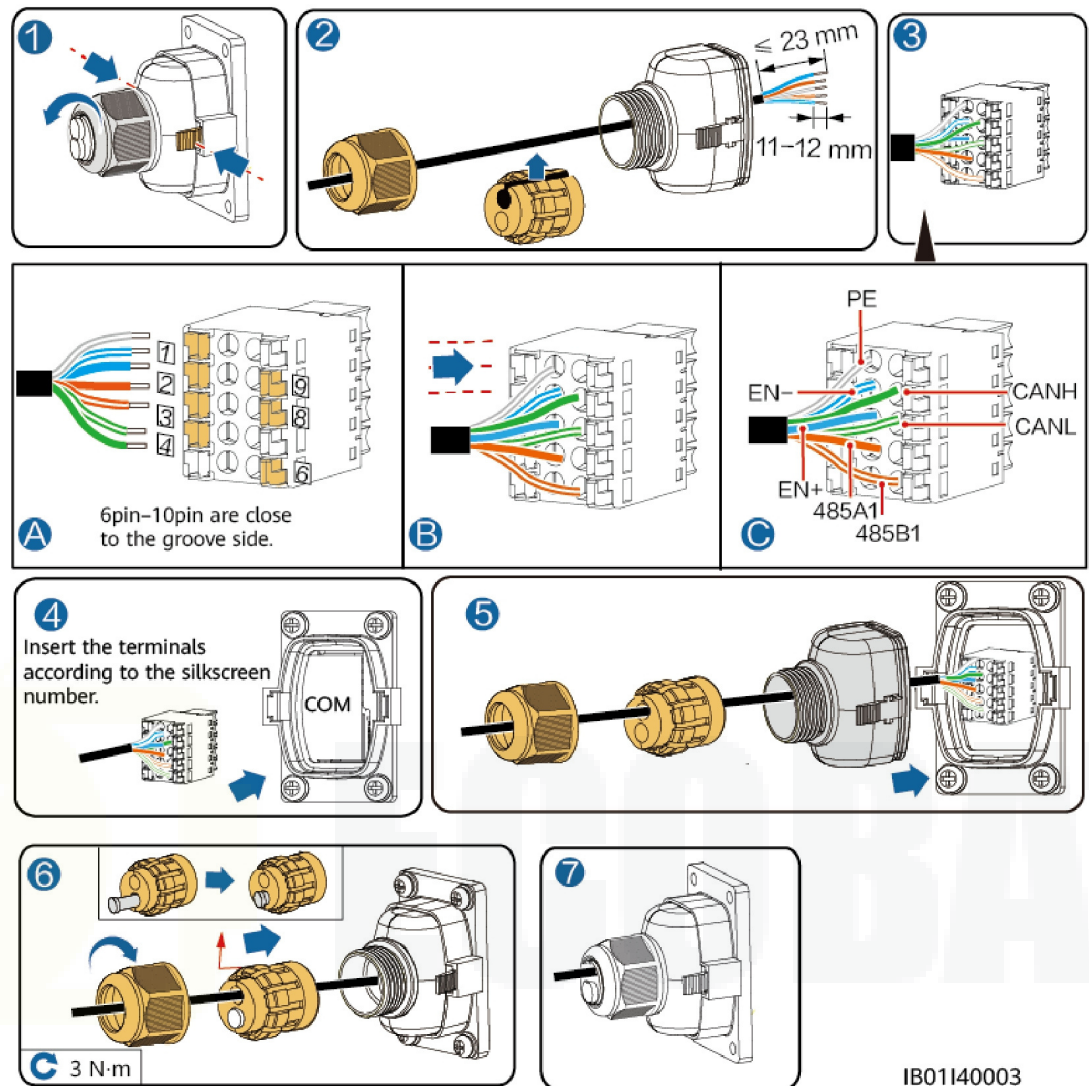

IB01140003

## 5.5 Installing the Cover

After electrical connections are complete, check that cables are correctly and securely connected, install the external protective cover, and secure it using screws.

Figure 5-16 Installing the cover

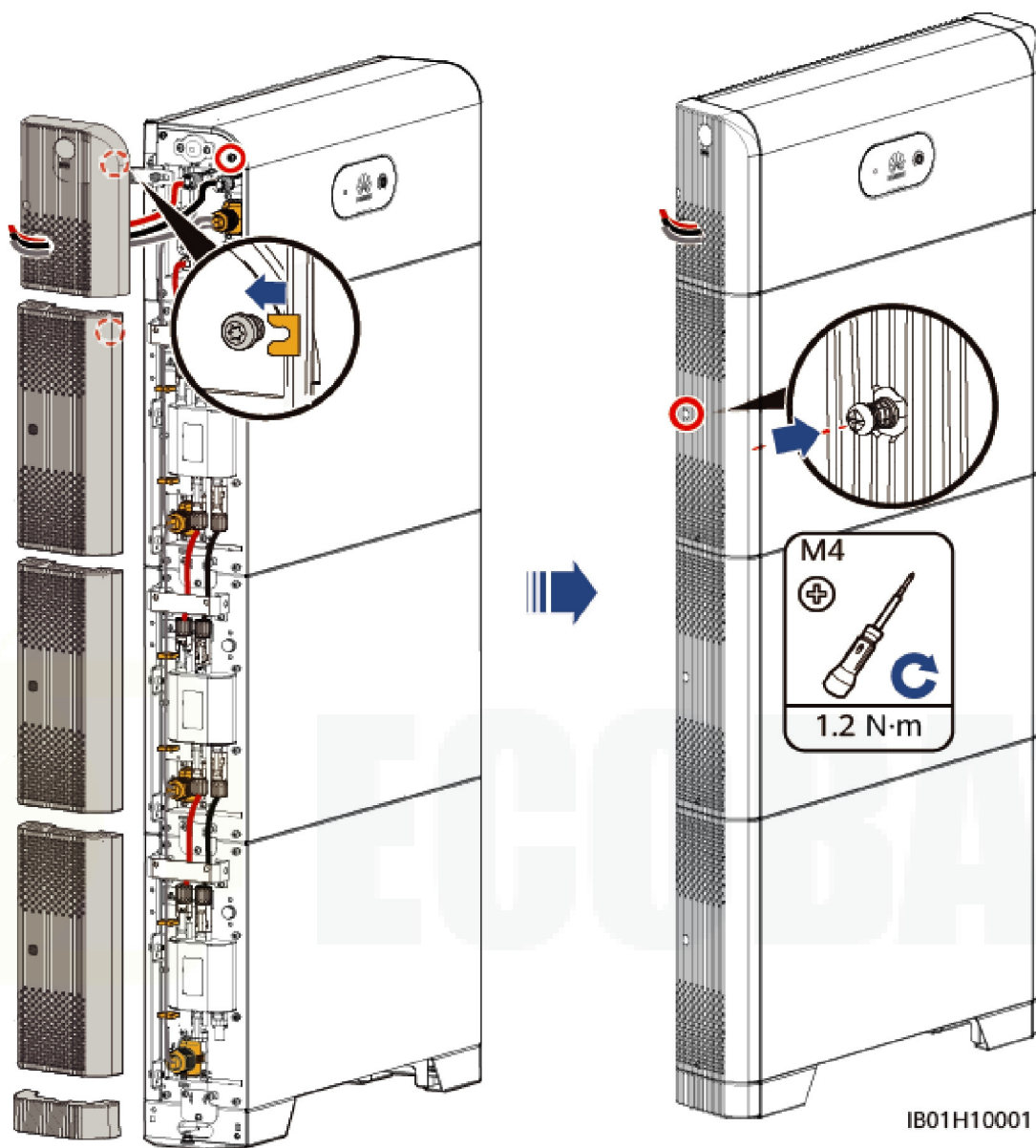

# 6 System Commissioning

## 6.1 Verification Before Power-On

Table 6-1 Check items and acceptance criteria

| No. | Check Item               | Acceptance Criteria   |
|-----|--------------------------|---|
| 1   | Battery installation     | The installation is correct and reliable.   |
| 2   | Cables routing           | Cables are routed properly as required by the customer.   |
| 3   | Cable tie                | Cable ties are evenly distributed and no burr exists.   |
| 4   | Grounding                | The PE cable is connected correctly, securely, and reliably.  |
| 5   | Switch                   | The DC switch and all switches connected to the battery are OFF.  |
| 6   | Cable connection         | The AC output power cable, DC input power cable, battery cable, and signal cable are connected correctly, securely, and reliably. |
| 7   | Unused terminal and port | Unused terminals and ports are locked by watertight caps.   |
| 8   | Installation environment | The installation space is proper, and the installation environment is clean and tidy.   |

## 6.2 System Power-On

### NOTICE

After turning on the battery switch, power on the inverter. For details about how to power on the inverter, see the quick guide for the corresponding inverter model.

### NOTE



If no PV module is configured, press the black start button first.

Turn on the DC switch on the battery. After the battery is installed and powered on for the first time, the ring LED blinks for three circles. Observe the battery indicator to check the running status.

## LED Indicators

LED indicator description

Table 6-2 LED indicators

| Category                 | Status (Blinking at Long Intervals: On for 1s and then Off for 1s; Blinking at Short Intervals: On for 0.2s and then Off for 0.2s) |   | Description                                |
|--------------------------|--|---|--|
| Running indicator        |   |  | N/A  |
|                          | Steady green   | Steady green  | Operating mode                             |
|                          | Blinking green slowly  | Blinking green slowly   | Standby mode                               |
|                          | Off  | Off   | Hibernation mode                           |
|                          | Blinking red fast  | N/A   | Power control module environment alarm     |
|                          | N/A  | Blinking red fast   | Battery expansion module environment alarm |
|                          | Steady red   | N/A   | The power control module is faulty.        |
|                          | N/A  | Steady red  | The battery expansion module is faulty.    |
|                          | Steady red   | Steady red  | Faulty                                     |
| Battery system indicator |   |   | N/A  |

| Category | Status (Blinking at Long Intervals: On for 1s and then Off for 1s; Blinking at Short Intervals: On for 0.2s and then Off for 0.2s) | Description   |
|----------|--|---|
|          | Green  | Battery level. Each bar indicates 10%.  |
|          | Steady red   | The first three bars indicate the number of faulty battery expansion modules. |

## 6.3 Battery Commissioning

### Download and install the FusionSolar app.

Download and install the latest FusionSolar app by referring to the quick guide for the corresponding inverter model or the *FusionSolar App Quick Guide*. Then register the installer and create a PV plant and owner (skip this step if the account has been created). You can obtain the *FusionSolar App Quick Guide* by scanning the following QR code.

Figure 6-1 FusionSolar App Quick Guide



### 6.3.1 Battery Deployment

#### Function

Add a battery and set the working mode on the quick settings screen of the inverter.

#### (Optional) Upgrading the Inverter and Dongle

When the app connects to the inverter, a message is displayed, asking you to upgrade the inverter version. Dongle V100R001C00SPC117 and later versions support LUNA2000 battery. But the Smart Dongle cannot be upgraded locally. You need to perform the upgrade through the management system. The operation procedure will be updated later.

#### Quick Settings

- Step 1** Log in to the FusionSolar app using the installer's account. Tap **Quick Settings** on the home screen to add the battery and set the battery working mode. By default, the battery working mode is set to the maximum self-consumption mode. Tap ? to view the detailed settings, and select a working mode by referring to [3 Application Scenarios and Settings](#).

Figure 6-2 Quick settings

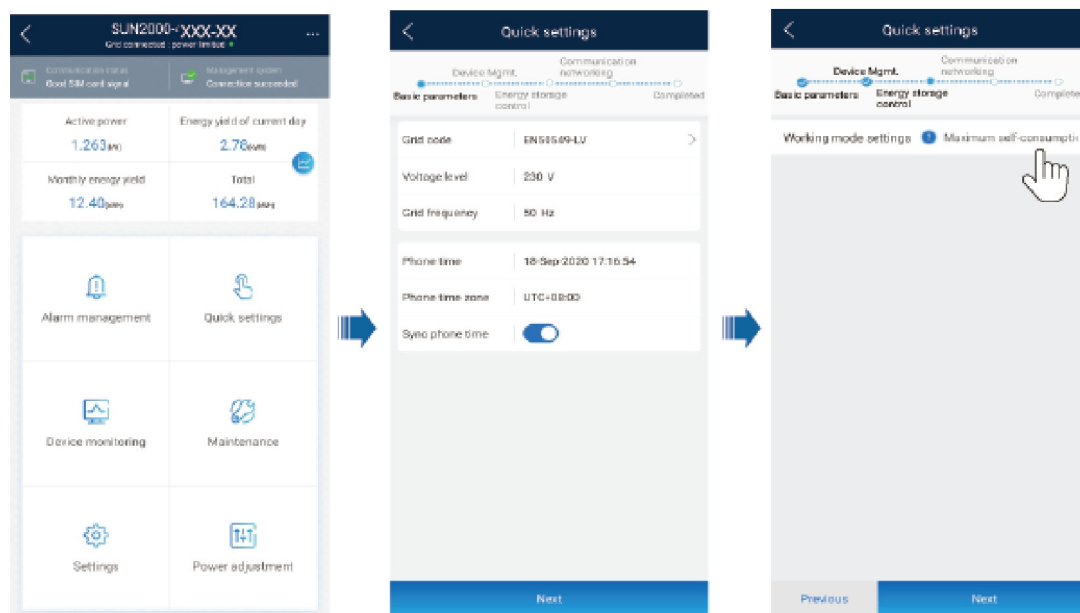

----End

### 6.3.2 Battery Control

#### Function

When the inverter connects to a battery, add the battery and set battery parameters.

#### Adding a Battery

To add a battery, choose **Maintenance > Subdevice management** on the home screen.



Figure 6-3 Adding a battery

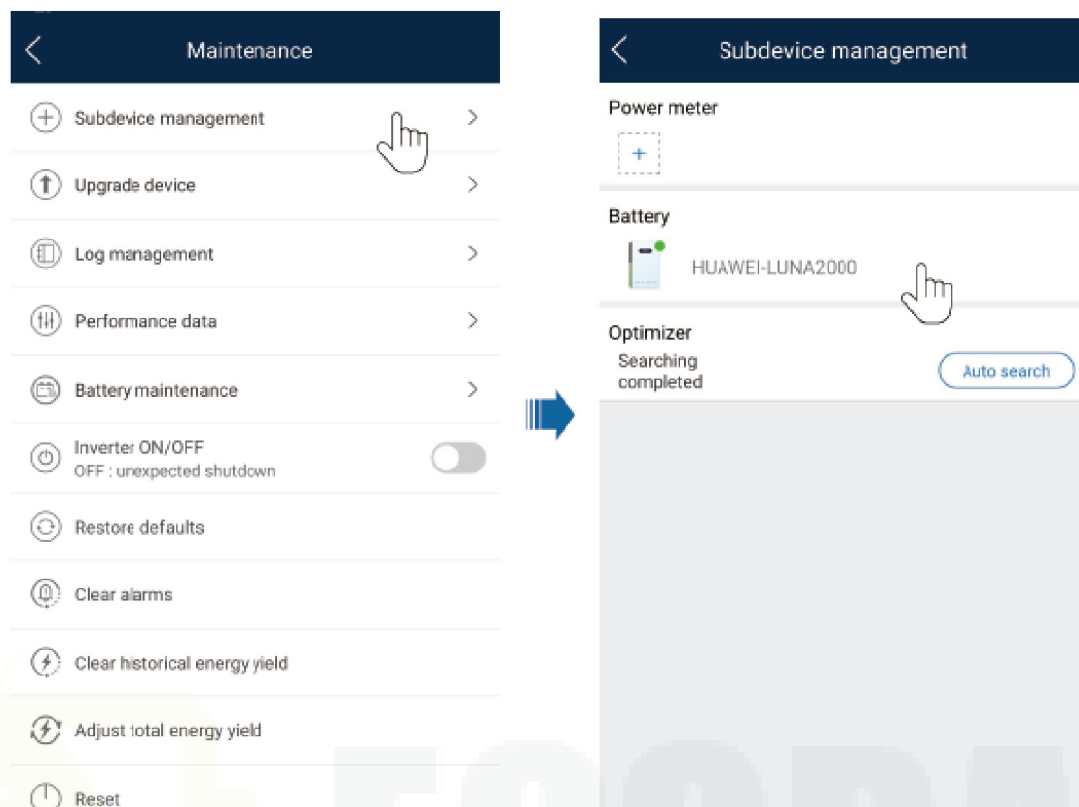

## Parameters Settings

On the home screen, choose **Power adjustment > Battery control**, and set the battery parameters and working mode.

**Figure 6-4** Battery control parameter setting

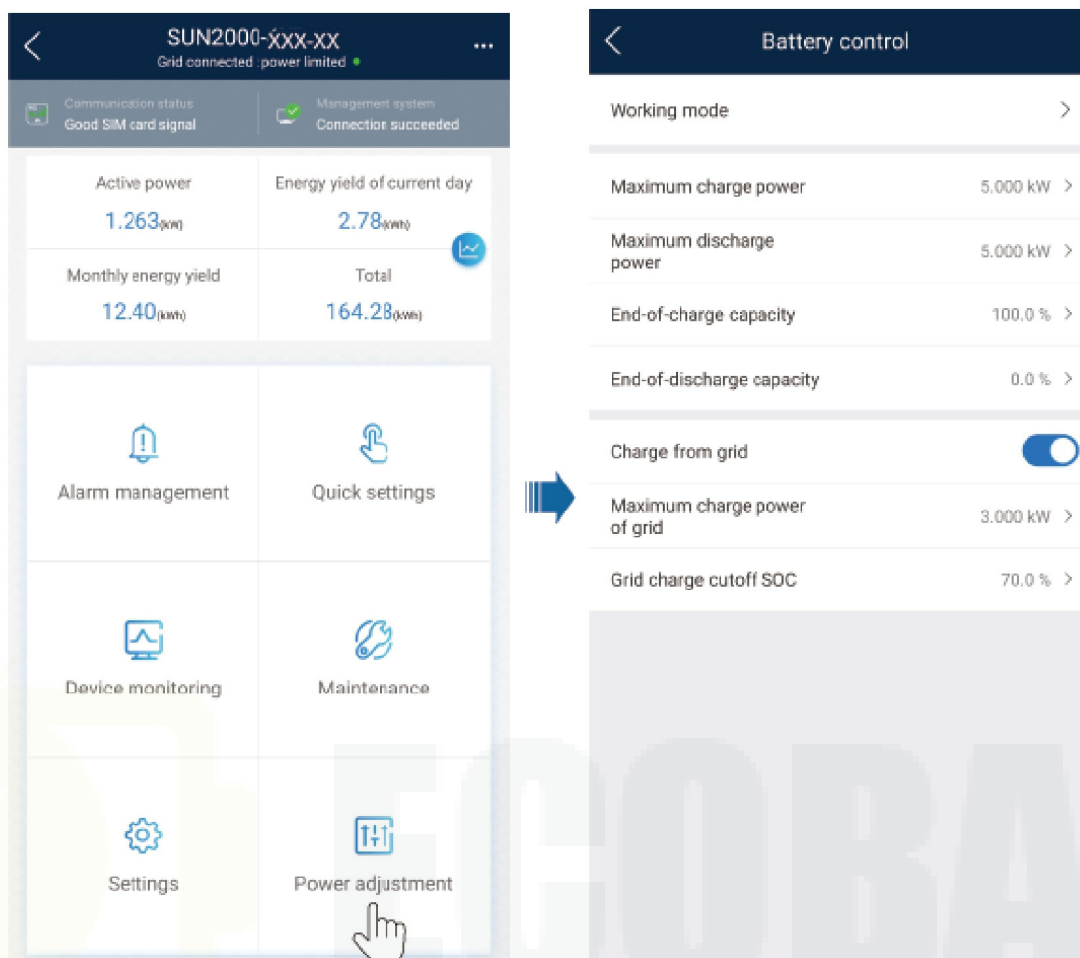

| Parameter                    | Description   | Value Range  |
|------------------------------|---|--|
| Working mode                 | For details, see the description on the app screen.   | <ul style="list-style-type: none"> <li>Maximum self-consumption</li> <li>Time-of-use</li> <li>Fully fed to grid</li> </ul> |
| Maximum charge power (kW)    | Retain this parameter to the maximum charge power. Additional configuration is not required.    | <ul style="list-style-type: none"> <li>Charge: [0, Maximum charge power]</li> </ul>  |
| Maximum discharge power (kW) | Retain this parameter to the maximum discharge power. Additional configuration is not required. | <ul style="list-style-type: none"> <li>Discharge: [0, Maximum discharge power]</li> </ul>                                  |

| Parameter                     | Description  | Value Range   |
|-------------------------------|--|---|
| End-of-charge capacity (%)    | Set the charge cutoff capacity.  | 80%–100%  |
| End-of-discharge capacity (%) | Set the charge cutoff capacity.  | 0%–20%  |
| Charge from grid              | If <b>Charge from grid</b> function is disabled by default, comply with the grid charge requirements stipulated in local laws and regulations when this function is enabled. | <ul style="list-style-type: none"> <li>• Disable</li> <li>• Enable</li> </ul> |
| Grid charge cutoff SOC        | Set the grid charge cutoff SOC.  | [0, 100%]   |

### 6.3.3 Querying the Battery Status

On the home screen, tap **Device monitoring** on the home screen to view the running status, level, power, and charge and discharge status of the battery.

Figure 6-5 Device monitoring

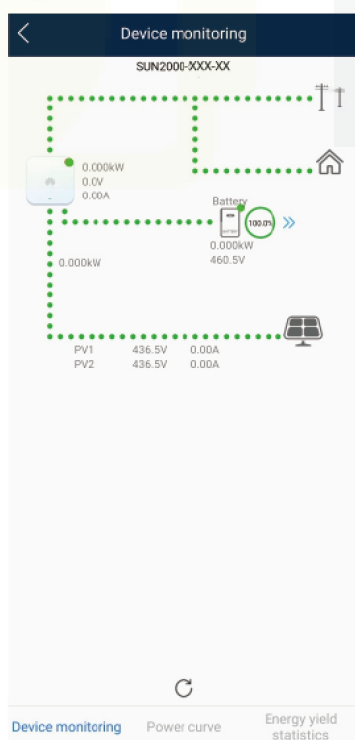

### 6.3.4 Battery Maintenance and Upgrade

On the home screen, choose **Maintenance > Battery upgrade** and set related parameters.

## Forced Charge and Discharge

**Step 1** Choose **Maintenance > Battery maintenance > Forced charge and discharge**, set forced charged and discharged parameters, and tap **Submit**.

**Figure 6-6** Forced Charge and Discharge

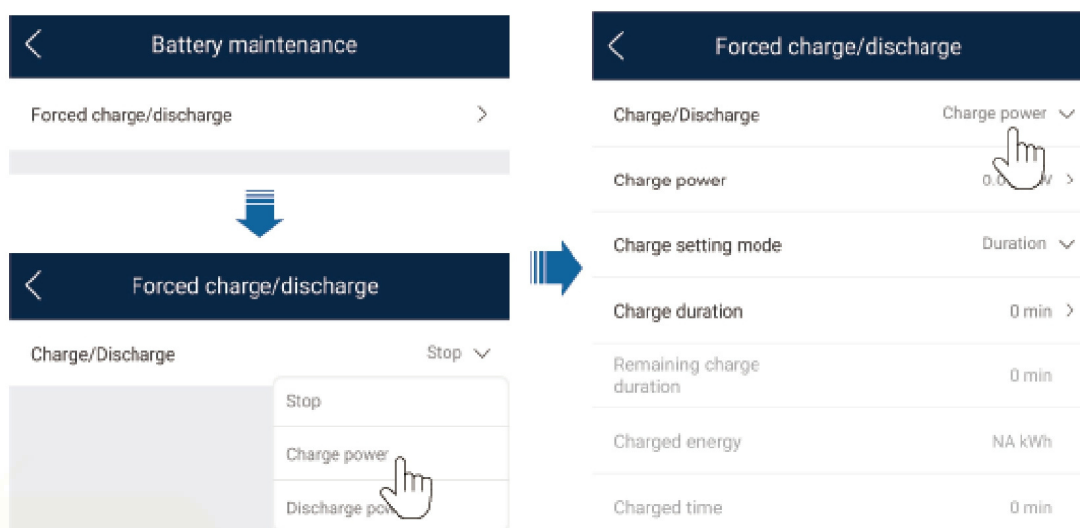

**Table 6-3** Description of forced charge/discharge parameters

| Parameter                                 | Description  | Value Range  |
|---|--|--|
| Charge/Discharge                          | Specifies whether to charge or discharge the battery.                                | <ul style="list-style-type: none"> <li>• Stop</li> <li>• Charge</li> <li>• Discharge</li> </ul>  |
| Charge/Discharge power (kW)               | Specifies the forced charge/discharge power.   | <ul style="list-style-type: none"> <li>• Charge: [0, Maximum charge power]</li> <li>• Discharge: [0, Maximum discharge power]</li> </ul> |
| Charge/Discharge setting mode             | Set the charge and discharge mode.   | <ul style="list-style-type: none"> <li>• Duration</li> <li>• Charged/Discharged energy</li> </ul>  |
| Charge/Discharge duration (min)           | Sets the charge and discharge duration.  | [0, 1440]  |
| Remaining charge/discharge duration (min) | Indicates the remaining charge and discharge duration. This parameter cannot be set. | -  |
| Charged/Discharged energy (kWh)           | Indicates the charged or discharged battery level. This parameter cannot be set.     | -  |

| Parameter                         | Description  | Value Range |
|-----------------------------------|--|-------------|
| Charged/Discharged duration (min) | Indicates the charged and discharged duration. This parameter cannot be set. | -           |

----End

## Downloading an Upgrade Package

Downloading an Upgrade Package

- Step 1** When your phone is connected to a network, on the connection screen, tap  in the upper right corner, and then choose **File download**.

**Figure 6-7** Downloading a file

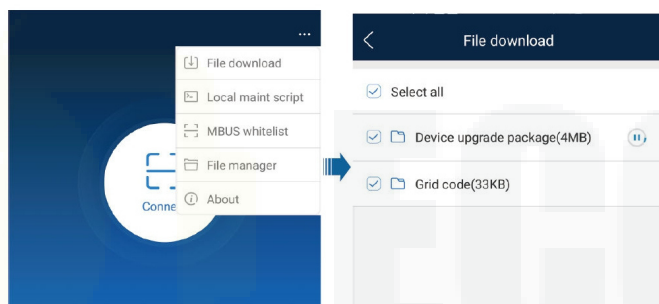

- Step 2** Download the device upgrade package and grid code when an update is detected.
- Step 3** On the screen for downloading the upgrade package, tap **Download**.

----End

# 7 System Maintenance

## 7.1 System Power-Off

### Precautions

 **WARNING**

After the system powers off, the remaining electricity and heat may still cause electric shocks and body burns. Therefore, wear protective gloves 5 minutes after the system is powered off before performing any operation on the battery.

After powering off the connected inverter, turn off the DC switch for the battery.

## 7.2 Routine Maintenance

To ensure that the battery can operate properly for a long term, you are advised to perform routine maintenance on it as described in this chapter.

 **CAUTION**

Before cleaning the system, connecting cables, and ensuring the grounding reliability, power off the system.

**Table 7-1** Maintenance checklist

| Check Item         | Check Method   | Maintenance Interval      |
|--------------------|--|---------------------------|
| System cleanliness | Check periodically that the heat sinks are free from obstacles and dust. | Once every 6 to 12 months |



| Check Item            | Check Method  | Maintenance Interval  |
|-----------------------|---|---|
| System running status | <ul style="list-style-type: none"> <li>• Check that the battery is not damaged or deformed.</li> <li>• Check that the battery does not generate abnormal sound when it is in operation.</li> <li>• Check that the battery parameters are correctly set when the battery is running.</li> </ul>                                  | Once every 6 months   |
| Electrical Connection | <ul style="list-style-type: none"> <li>• Check that cables are secured.</li> <li>• Check that cables are intact, and that in particular, the parts touching the metallic surface are not scratched.</li> <li>• Check that unused DC input terminals, battery terminals, and COM ports are locked by watertight caps.</li> </ul> | The first inspection is 6 months after the initial commissioning. From then on, the interval can be 6 to 12 months. |
| Grounding reliability | Check that ground cables are securely connected.  | The first inspection is 6 months after the initial commissioning. From then on, the interval can be 6 to 12 months. |

## 7.3 Troubleshooting

Alarm severities are defined as follows:

- Major: The battery shuts down or some functions are abnormal due to a fault.
- Minor: Some components of the battery are faulty but the battery can still work.

**Table 7-2** Common alarms and troubleshooting measures

| Alarm ID | Alarm Name                                   | Alarm Severity | Possible Cause  | Troubleshooting  |
|----------|--|----------------|---|--|
| 3000     | Low battery DC input bus voltage             | Major          | <ol style="list-style-type: none"> <li>1. The DC bus voltage of the battery is low.</li> <li>2. The battery DC switch is OFF.</li> <li>3. The battery cables are not correctly connected.</li> </ol>  | <ol style="list-style-type: none"> <li>1. Turn off the inverter AC output switch, inverter DC input switch, and battery DC switch, and wait for 5 minutes.</li> <li>2. Check the cable connections to the [Battery-1/2] power control module by referring to the quick installation guide.</li> <li>3. After checking that the battery power cables are correctly connected, turn on the battery DC switch, AC output switch, and inverter DC input switch in sequence.</li> <li>4. If the alarm persists, contact your dealer or Huawei technical support.</li> </ol> |
| 3001     | Abnormal battery power control module        | Major          | An unrecoverable fault has occurred on an internal circuit of the battery power control module.   | <ol style="list-style-type: none"> <li>1. Turn off the inverter AC output switch, inverter DC input switch, and battery DC switch, and wait for 5 minutes.</li> <li>2. Turn on the battery DC switch, inverter AC output switch, and DC input switch.</li> <li>3. If the alarm persists on the [Battery-1/2] power control module (the battery fault indicator is steady on), contact your dealer or Huawei technical support.</li> </ol>  |
| 3002     | Battery power control module overtemperature | Minor          | <ol style="list-style-type: none"> <li>1. The installation position of the battery power control module is not well ventilated.</li> <li>2. The ambient temperature is excessively high.</li> <li>3. The battery power control module is abnormal.</li> </ol> | <ol style="list-style-type: none"> <li>1. Check the ventilation and whether the ambient temperature of the [Battery-1/2] power control module exceeds the upper threshold.</li> <li>2. If the ventilation is poor or the ambient temperature is excessively high, improve the ventilation and heat dissipation.</li> <li>3. If the ventilation and ambient temperature are normal, contact your dealer or Huawei technical support.</li> </ol>   |

| Alarm ID | Alarm Name                                       | Alarm Severity | Possible Cause  | Troubleshooting  |
|----------|--|----------------|---|--|
| 3003     | Battery power control module fuse blown          | Major          | The fuse of the battery power control module is blown.  | <ol style="list-style-type: none"> <li>1. Turn off the inverter AC output switch, inverter DC input switch, and battery DC switch, and wait for 5 minutes.</li> <li>2. Replace the fuse of the [Battery-1/2] power control module.</li> <li>3. Turn on the battery DC switch, inverter AC output switch, and inverter DC input switch in sequence. If the alarm persists, contact your dealer or Huawei technical support.</li> </ol>  |
| 3004     | Battery power control module reversely connected | Major          | The positive and negative terminals are reversely connected when the battery power control module connects to the inverter. | <ol style="list-style-type: none"> <li>1. Turn off the inverter AC output switch, inverter DC input switch, and battery DC switch, and wait for 5 minutes.</li> <li>2. Check the cable connections to the [Battery-1/2] power control module by referring to the quick installation guide.</li> <li>3. After checking that the battery power cables are correctly connected, turn on the battery DC switch, AC output switch, and inverter DC input switch in sequence.</li> <li>4. If the alarm persists, contact your dealer or Huawei technical support.</li> </ol> |

| Alarm ID | Alarm Name                                 | Alarm Severity | Possible Cause   | Troubleshooting   |
|----------|--|----------------|--|---|
| 3005     | Battery power control module DC switch OFF | Warning        | <ol style="list-style-type: none"> <li>1. The DC switch of the battery power control module is OFF.</li> <li>2. The DC bus cable to the battery power control module is disconnected.</li> </ol> | <ol style="list-style-type: none"> <li>1. Turn off the inverter AC output switch, inverter DC input switch, and battery DC switch, and wait for 5 minutes.</li> <li>2. Check the cable connections to the [Battery-1/2] power control module by referring to the quick guide.</li> <li>3. After checking that the battery power cables are correctly connected, turn on the battery DC switch, AC output switch, and inverter DC input switch in sequence.</li> <li>4. If the alarm persists, contact your dealer or Huawei technical support.</li> </ol>         |
| 3006     | Abnormal battery expansion module          | Major          | An unrecoverable fault has occurred on an internal circuit of a battery expansion module.  | <ol style="list-style-type: none"> <li>1. Check that the power cables and communications cables are correctly connected to the [Battery-1/2 battery expansion module-1/2/3] battery expansion modules.</li> <li>2. Send a shutdown command on the app, turn off the inverter AC output switch, inverter DC input switch, and battery DC switch, and wait for 5 minutes.</li> <li>3. Turn on the battery DC switch, inverter AC output switch, and DC input switch.</li> <li>4. If the alarm persists, contact your dealer or Huawei technical support.</li> </ol> |

| Alarm ID | Alarm Name                                  | Alarm Severity | Possible Cause  | Troubleshooting  |
|----------|---|----------------|---|--|
| 3007     | Battery expansion module cable disconnected | Major          | <ol style="list-style-type: none"> <li>1. A battery expansion module cable is disconnected.</li> <li>2. A battery expansion module is abnormal.</li> </ol>  | <ol style="list-style-type: none"> <li>1. Turn off the inverter AC output switch, inverter DC input switch, and battery DC switch, and wait for 5 minutes.</li> <li>2. Check whether the power cable is securely connected to the [Battery-1/2 battery expansion module-1/2/3] battery expansion modules (the terminal is loose or disconnected, or the cable is disconnected). For details, see the quick installation guide.</li> <li>3. After checking that the cables are correctly connected, turn on the battery DC switch, AC output switch, and inverter DC input switch in sequence.</li> <li>4. If the alarm persists, contact your dealer or Huawei technical support.</li> </ol> |
| 3008     | Battery expansion module overtemperature    | Minor          | <ol style="list-style-type: none"> <li>1. The battery installation position is not well ventilated.</li> <li>2. The ambient temperature is excessively high.</li> <li>3. The battery power control module is abnormal.</li> </ol> | <ol style="list-style-type: none"> <li>1. Check the ventilation and whether the ambient temperature of the [Battery-1/2 battery expansion module-1/2/3] battery expansion modules exceeds the upper threshold.</li> <li>2. If the ventilation is poor or the ambient temperature is excessively high, improve the ventilation and heat dissipation.</li> <li>3. If the ventilation and ambient temperature are normal, contact your dealer or Huawei technical support.</li> </ol>   |



| Alarm ID | Alarm Name                               | Alarm Severity | Possible Cause  | Troubleshooting   |
|----------|--|----------------|---|---|
| 3009     | Battery expansion module low temperature | Minor          | <ol style="list-style-type: none"> <li>1. The ambient temperature is excessively low.</li> <li>2. A battery expansion module is abnormal.</li> </ol>      | <ol style="list-style-type: none"> <li>1. Check whether the ambient temperature in the installation positions of the [Battery-1/2 battery expansion module-1/2/3] battery expansion modules is lower than the lower threshold.</li> <li>2. If the ambient temperature is excessively low, improve the installation environment.</li> <li>3. If the alarm persists after the ambient temperature becomes normal, contact your dealer or Huawei technical support.</li> </ol>   |
| 3010     | Battery expansion module short circuit   | Major          | <ol style="list-style-type: none"> <li>1. The battery expansion module is short-circuited.</li> <li>2. A battery expansion module is abnormal.</li> </ol> | <ol style="list-style-type: none"> <li>1. Turn off the inverter AC output switch, inverter DC input switch, and battery DC switch, and wait for 5 minutes.</li> <li>2. Check the power cable connection to the [Battery-1/2 battery expansion module-1/2/3] battery expansion modules by referring to the quick installation guide. If the cable is damaged or short-circuited, replace it.</li> <li>3. After checking that the cables are correctly connected, turn on the battery DC switch, AC output switch, and inverter DC input switch in sequence.</li> <li>4. If the alarm persists, contact your dealer or Huawei technical support.</li> </ol> |
| 3011     | Battery expansion module undervoltage    | Warning        | The voltage of a battery expansion module is low.   | If the sunlight is sufficient or AC reverse charging is allowed, the [Battery-1/2 battery expansion module-1/2/3] battery expansion modules can be charged when the inverter is running.  |



| Alarm ID | Alarm Name   | Alarm Severity | Possible Cause  | Troubleshooting   |
|----------|--|----------------|---|---|
| 3012     | Abnormal battery power control module parallel communication | Major          | The battery power control modules of the parallel system fail to communicate with each other. | <ol style="list-style-type: none"> <li>1. Send a shutdown command on the app, turn off the inverter AC output switch, inverter DC input switch, and battery DC switch, and wait for 5 minutes.</li> <li>2. Check that the communications cable is correctly connected between the [Battery-1/2] battery power control modules of the parallel system.</li> <li>3. After checking that the cables are correctly connected, turn on the battery DC switch, AC output switch, and inverter DC input switch in sequence.</li> <li>4. If the alarm persists, contact your dealer or Huawei technical support.</li> </ol> |
| 3013     | Abnormal battery expansion module communication              | Major          | The battery power control module fails to communicate with the battery expansion modules.     | <ol style="list-style-type: none"> <li>1. Turn off the battery DC switch.</li> <li>2. Check that the power cables and communications cables are correctly connected to the [Battery-1/2 battery expansion module-1/2/3] battery expansion modules.</li> <li>3. After checking that cables are correctly connected, turn on the battery DC switch.</li> <li>4. If the alarm persists, contact your dealer or Huawei technical support.</li> </ol>  |

## 7.4 Battery Storage and Recharge

### Battery Acceptance Inspection

A battery recharge label must be put on the battery packing case. The recharge label should contain the latest charge time and the next recharge time.

### Battery Storage Requirements

1. Place batteries according to the signs on the packing case during storage. Do not put batteries upside down or sidelong.

2. Stack battery packing cases by complying with the stacking requirements on the external package.
3. Handle batteries with caution to avoid damage.
4. The storage environment requirements are as follows:
  - Ambient temperature: 0–40°C; recommended storage temperature: 20–30°C
  - Relative humidity: 5% to 80%
  - Place batteries in a dry and clean place with proper ventilation.
  - Place batteries in a place that is away from corrosive organic solvents and gases.
  - Keep batteries away from direct sunlight.
  - Keep batteries at least 2 meters away from heat sources.
5. The batteries in storage must be disconnected from external devices. The indicators (if any) on the batteries should be off.
6. AC mains input voltage requirements in the recharge places: single-phase power grid: 220 V/230 V/240 V, ±10%; three-phase voltage: 380 V/400 V, ±10%.
7. The warehouse keeper should collect battery storage information every month and periodically report the battery inventory information to the planning department. The batteries that have been stored for nearly 15 months (0–25°C) or 8 months (25–40°C) should be recharged in a timely manner.
8. Regional offices or organizations should not store batteries.
9. Batteries should be delivered based on the "first in, first out" rule.
10. After the battery production test is complete and before the batteries are stored, the batteries must be recharged to at least 50% of the SOC.

### Conditions for Judging Overdue Storage

It is recommended that batteries not be stored for a long period. They should be used soon after being deployed onsite. The batteries should be handled according to the following requirements.

**Table 7-3** Lithium battery recharge interval

| Required Storage Temperature | Actual Storage Temperature                         | Recharge Interval | Remarks   |
|------------------------------|--|-------------------|---|
| 0°C–40°C                     | $0^{\circ}\text{C} \leq T \leq 25^{\circ}\text{C}$ | 15 months         | Not reaching the time for recharge: Use the batteries as soon as possible.<br>Reaching the time for recharge: Recharge the batteries. |

| Required Storage Temperature | Actual Storage Temperature | Recharge Interval | Remarks   |
|------------------------------|----------------------------|-------------------|---|
|                              | 25°C < T ≤ 40°C            | 8 months          | The total storage duration should not exceed the warranty period. |

1. Dispose of deformed, damaged, or leaking batteries directly irrespective of how long they have been stored.
2. The storage duration starts from the latest charge time labeled on the battery package. If a battery is qualified after recharge, update the latest charge time and the next recharge time (next recharge time = latest charge time + recharge interval) on the label.
3. The maximum power storage period of a lithium battery is three years. A lithium battery can be recharged at most for three times within the three years. For example, it can be recharged every 8 months or every 12 months. It is recommended that batteries be scrapped if the maximum allowable storage period and recharging times are exceeded.
4. If a lithium battery is stored for a long time, capacity loss may occur. After a lithium battery is stored for 12 months in the recommended storage temperature, the irreversible capacity loss rate is 3%–10%. If customers perform the discharge test according to the specifications, they may fail to pass the test if the storage capacity of the battery is not 100% of the rated capacity.

### Inspection Before Recharge

1. Before recharging a battery, you need to check its appearance. Recharge the battery if it is qualified or dispose of it if not.
2. The battery is qualified if it is free from the following symptoms:
  - Deformation
  - Shell damage
  - Leakage

### Battery Recharging Scenarios

#### Three-Phase Power Supply Scenario

- The three-phase 10 kW inverter provides 10 kW power to charge batteries. It allows two charge units (six battery packs) to be charged at the same time. Other models can charge batteries with a power of less than 10 kW.

**Figure 7-1** Networking diagram for three-phase power supply scenario

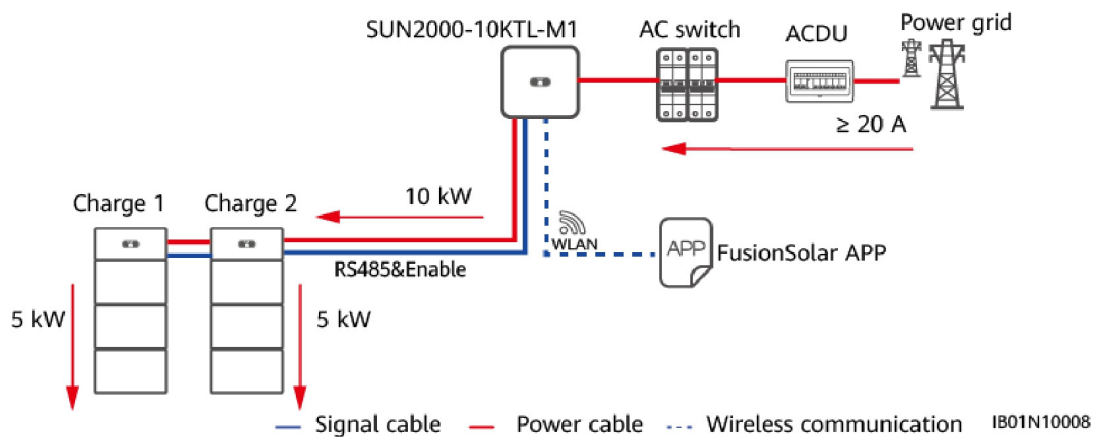

### Single-phase power supply scenario

- The SUN2000-(3KTL-6KTL)-L1 provides 3 kW power to charge batteries. It allows one charge unit (three battery packs) to be charged at the same time.

**Figure 7-2** Networking diagram for single-phase power supply scenario

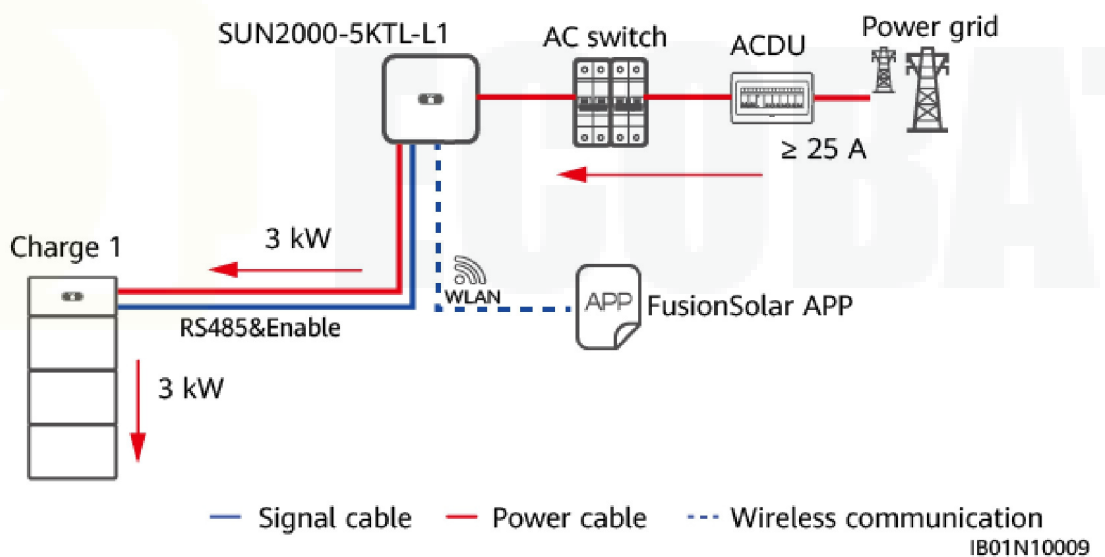

### Battery Recharging Cable Connection

Connect cables by referring to [5 Electrical Connection](#). If two charge units need to be charged at the same time, cascade the batteries by referring to [5.4 \(Optional\) Cascading Batteries](#).

Figure 7-3 Cable connection diagram

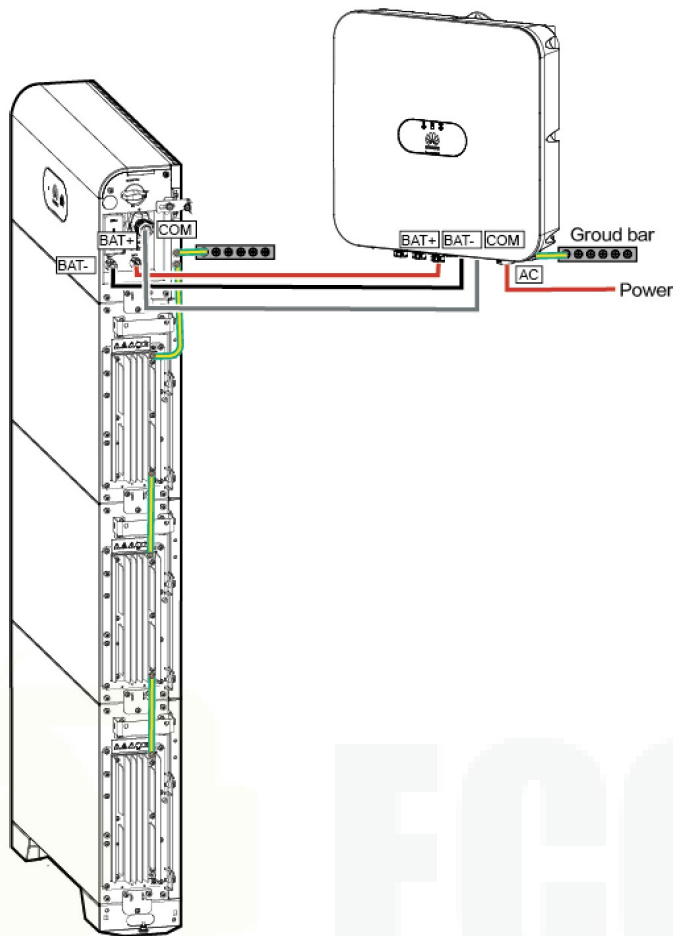

## Battery Power-On and Commissioning

- For details about how to store and recharge the battery, see the *Lithium Battery Storage and Recharge Guide*.

---

### NOTICE

- Ensure that the charge process is supervised to prevent any abnormality.
- If a battery experiences an abnormality such as bulging or smoking, stop charging immediately and dispose of it.
- Ensure that only trained professionals perform recharge operations.
- After turning on the battery switch, power on the inverter. For details about how to power on the inverter, see the quick guide for the corresponding inverter model.

---

**Step 1** Connect power cables and communications cables correctly.

**Step 2** Turn on the battery power pack switch by turning the DC switch to ON.

**Step 3** Turn on the AC switch between the inverter and the grid.

**Step 4** Check that LED1 is steady green, LED2 is steady green, and LED3 is blinking green slowly.



**Step 5** Hold down the black start button for 5s to activate the battery. The power control module LED blinks three times and then the green indicator is steady on. The battery comprehensive LED blinks three times and then the green indicator is steady on. The ring LED blinks three circles.

**Step 6** Connect the FusionSolar app to the inverter, choose **Maintenance > Battery maintenance > Recharge**, start battery recharge, and monitor the charge status of the lithium battery in real time until the recharge is complete.

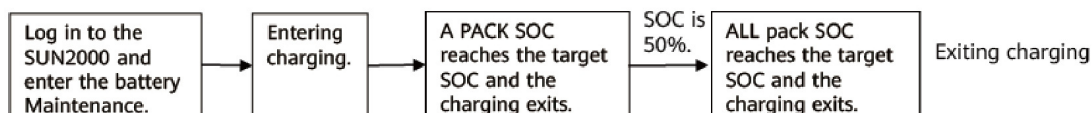

**Step 7** Confirm that the recharge is complete if five indicators of the ring LED are on and the comprehensive LED of the battery expansion modules is steady green.

**Step 8** After the battery is charged, switch off the inverter input AC circuit breaker and then the battery input circuit breaker. If other batteries need to be charged, repeat the preceding steps.

----End





# 8 Technical Specifications

## 8.1 LUNA2000-5KW-C0

| Technical Specifications                | LUNA2000-5KW-C0               |
|---|-------------------------------|
| Rated charge and discharge power        | 5 kW                          |
| Nominal voltage (three-phase system)    | 360 V                         |
| Operating voltage (single-phase system) | 350–560 V                     |
| Nominal voltage (three-phase system)    | 600 V                         |
| Operating voltage (three-phase system)  | 600–980 V                     |
| Dimensions (H x W x D)                  | 240 mm x 670 mm x 150 mm      |
| Weight                                  | 12 kg                         |
| Cooling mode                            | Free cooling                  |
| IP rating                               | IP65                          |
| Communications                          | RS485 and CAN (for cascading) |
| Operating temperature                   | -25°C to +55°C                |
| Operating humidity                      | 5%–95% RH                     |
| Maximum operating altitude              | 4000 m                        |

## 8.2 LUNA2000-5-E0

| Technical Specifications   | LUNA2000-5-E0            |
|----------------------------|--------------------------|
| Nominal available capacity | 5 kWh                    |
| Battery cell type          | Li-ion                   |
| Dimensions (H x W x D)     | 360 mm x 670 mm x 150 mm |
| Weight                     | 50kg                     |
| Cooling mode               | Free cooling             |
| IP rating                  | IP65                     |
| Operating temperature      | -10°C to +55°C           |
| Maximum operating altitude | 4000 m                   |

# 9 FAQ

## 9.1 How Do I Replace a Fuse?

**Step 1** Power off the system. For details, see [7.1 System Power-Off](#).

**⚠ WARNING**

After the system is powered off, the remaining electricity and heat still exist in the chassis, which may cause electric shocks or burns. Therefore, you need to wear protective gloves and perform operations 5 minutes after the system is powered off.

**Step 2** Loosen the screws on the fuse shell.

**Figure 9-1** Removing the screw shell

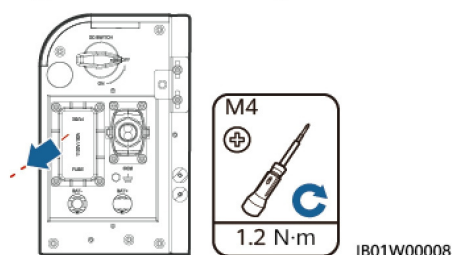

**Step 3** Lift the fuse box opening, remove the fuse, insert a new fuse into the slot, and close the fuse box. If you hear a click sound and the bulge on the side is inside the box, the fuse box is properly installed.

**Figure 9-2** Replacing a fuse

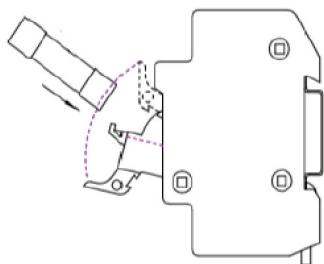

----End

## Fuse Specifications

**Table 9-1** Fuse specifications

| Fuse  | Required Specifications |                |             |
|---|-------------------------|----------------|-------------|
|   | Lower Limit             | Typical Value  | Upper Limit |
| Type  | -                       | Fuse           | -           |
| Component type  | -                       | Fuse           | -           |
| Fuse type   | -                       | Fast blow fuse | -           |
| Rated voltage (V AC&V DC)   | 1100 V DC               | -              | -           |
| Rated current   | 32 A                    | -              | -           |
| Breaking capacity   | 10 kA                   | -              | -           |
| Nominal fusing heat I <sup>2</sup> T  | -                       | -              | -           |
| Cold resistance value   | -                       | -              | 0.005 Ω     |
| Package dimensions (the dimension tolerance should be specified in the specifications provided by the supplier) | -                       | 14 mm x 51 mm  | -           |

# A Acronyms and Abbreviations

---

|            |                              |
|------------|------------------------------|
| <b>A</b>   |                              |
| <b>APP</b> | application                  |
| <b>B</b>   |                              |
| <b>BMS</b> | battery management system    |
| <b>D</b>   |                              |
| <b>DC</b>  | direct current               |
| <b>F</b>   |                              |
| <b>FIT</b> | feed-in tariff               |
| <b>E</b>   |                              |
| <b>EMI</b> | electromagnetic interference |
| <b>P</b>   |                              |
| <b>PV</b>  | photovoltaic                 |
| <b>V</b>   |                              |
| <b>VPP</b> | virtual power plant          |

# AVANTAJE EXCLUSIVISTE INSTALATORI & REVÂNZĂTORI B2B



**Preturi  
dedicate**  
**Pentru Instalatori  
& Revânzători**



**Stoc  
permanent  
în România**



**Termene  
de plată**  
**Până la 90 zile**



**Livrare  
imediată**  
**24 - 48 ore**



**01** **Prețuri dedicate**  
Pentru **Instalatori**  
& **Revânzători**

A small yellow icon of a discount tag with a percentage symbol, located on the right side of the header box.

Punem accent pe parteneriatele noastre și recunoaștem rolul vital pe care îl jucați în industria energiei solare.

De aceea, oferim prețuri dedicate și competitive pentru instalatori și revânzători.

Aveți avantajul de a obține produsele noastre la costuri atractive, ceea ce vă permite să maximizați profitabilitatea și să oferiți prețuri competitive clienților dumneavoastră.

**Suntem aici să creștem împreună.**

**02** **Stoc permanent**  
Stoc permanent în România 

Avem un stoc amplu de echipamente fotovoltaice în depozitul nostru din România.

Acest lucru ne permite să vă oferim posibilitatea de a ridica produsele imediat după comandă.

Nu trebuie să vă faceți griji cu privire la disponibilitatea sau întârzierile în livrare.

Suntem aici pentru a vă asigura că aveți acces rapid la echipamentele necesare pentru proiectele dvs.

## Termene de plată

03

Termene de plată  
De până la **90 de zile**



Înțelegem că gestionarea fluxului de numerar este esențială în afacerea dumneavoastră.

Prin parteneriatul cu Ecobat Energy, puteți beneficia de **termene de plată extinse de până la 90 de zile**.

Aceasta vă oferă flexibilitate financiară și vă permite să vă gestionați resursele într-un mod eficient.

Lucrând cu **Ecobat Energy**, veți avea un partener de încredere, **importator direct**, care vă oferă toate facilitățile necesare pentru a vă dezvolta afacerea în domeniul energiei solare.

## Livrare imediată

04

Livrare în 24-48 de ore  
oriunde în România



Înțelegem importanța unei livrări rapide și eficiente, într-o piață din ce în ce mai concurențială.

Cunoaștem urgența cu care utilizatorul final își dorește să finalizeze proiectul.

Colaborând cu Ecobat Energy, beneficiați de livrarea comenzilor dvs. în termen de 24-48 de ore, indiferent de locația din România.

Ne angajăm să vă furnizăm produsele la timp, astfel încât să puteți continua proiectele în mod eficient.



**Ești instalator sau revânzător de echipamente fotovoltaice?**

**Devino partener B2B **EcobatEnergy** și beneficiază acum de toate avantajele exclusive.**

**[www.ecobatenergy.ro](http://www.ecobatenergy.ro)**

**[office@ecobatenergy.ro](mailto:office@ecobatenergy.ro)**

**0786.913.321**